

# WORKSHOP CALCULATION & SCIENCE

(NSQF)

2<sup>nd</sup> YEAR

(As per Revised Syllabus July 2022)

**Aeronautical Structure and Equipment Fitter**



Directorate General of Training

DIRECTORATE GENERAL OF TRAINING  
MINISTRY OF SKILL DEVELOPMENT & ENTREPRENEURSHIP  
GOVERNMENT OF INDIA



**NATIONAL INSTRUCTIONAL  
MEDIA INSTITUTE, CHENNAI**

Post Box No. 3142, CTI Campus, Guindy, Chennai - 600 032

## **Workshop Calculation & Science**

### **Aeronautical Structure and Equipment Fitter - 2<sup>nd</sup> Year NSQF**

**As per Revised Syllabus July 2022**

#### **Developed & Published by**



#### **National Instructional Media Institute**

Post Box No.3142

Guindy, Chennai - 600032

INDIA

Email: [chennai-nimi@nic.in](mailto:chennai-nimi@nic.in)

Website: [www.nimi.gov.in](http://www.nimi.gov.in)

Copyright © 2023 National Instructional Media Institute, Chennai

First Edition : December 2023

Copies: 1000

**Rs: 95/-**

All rights reserved.

No part of this publication can be reproduced or transmitted in any form or by any means, electronic or mechanical, including photocopy, recording or any information storage and retrieval system, without permission in writing from the National Instructional Media Institute, Chennai.

## FOREWORD

The Government of India has set an ambitious target of imparting skills one out of every four Indians, to help them secure jobs as part of the National Skills Development Policy. Industrial Training Institutes (ITIs) play a vital role in this process especially in terms of providing skilled manpower. Keeping this in mind, and for providing the current industry relevant skill training to Trainees, ITI syllabus has been recently updated with the help of comprising various stakeholder's viz. Industries, Entrepreneurs, Academicians and representatives from ITIs.

The National Instructional Media Institute (NIMI), Chennai, has now come up with instructional material to suit the revised curriculum for **Workshop Calculation & Science - Aeronautical Structure and Equipment Fitter 2<sup>nd</sup> Year** NSQF (Revised 2022) under CTS will help the trainees to get an international equivalency standard where their skill proficiency and competency will be duly recognized across the globe and this will also increase the scope of recognition of prior learning. NSQF trainees will also get the opportunities to promote life long learning and skill development. I have no doubt that with NSQF the trainers and trainees of ITIs, and all stakeholders will derive maximum benefits from these IMPs and that NIMI's effort will go a long way in improving the quality of Vocational training in the country.

The Director General of Training, Executive Director & Staff of NIMI and members of Media Development Committee deserve appreciation for their contribution in bringing out this publication.

Jai Hind

**ATUL KUMAR TIWARI, I.A.S.**

Secretary  
Ministry of Skill Development & Entrepreneurship,  
Government of India.

December 2023  
New Delhi - 110 001

## PREFACE

The National Instructional Media Institute(NIMI) was set up at Chennai, by the Directorate General of Training, Ministry of skill Development and Entrepreneurship, Government of India, with the technical assistance from the Govt of the Federal Republic of Germany with the prime objective of developing and disseminating instructional Material for various trades as per prescribed syllabus and Craftsman Training Programme(CTS) under NSQF levels.

The Instructional materials are developed and produced in the form of Instructional Media Packages (IMPs), consisting of Trade Theory, Trade Practical, Test and Assignment Book, Instructor Guide and Wall charts. The above material will enable to achieve overall improvement in the standard of training in ITIs.

A national multi-skill programme called SKILL INDIA, was launched by the Government of India, through a Gazette Notification from the Ministry of Finance (Dept of Economic Affairs), Govt of India, dated 27th December 2013, with a view to create opportunities, space and scope for the development of talents of Indian Youth, and to develop those sectors under Skill Development.

The emphasis is to skill the Youth in such a manner to enable them to get employment and also improve Entrepreneurship by providing training, support and guidance for all occupation that were of traditional types. The training programme would be in the lines of International level, so that youths of our Country can get employed within the Country or Overseas employment. The **National Skill Qualification Framework (NSQF)**, anchored at the National Skill Development Agency(NSDA), is a Nationally Integrated Education and competency-based framework, to organize all qualifications according to a series of **levels of Knowledge, Skill and Aptitude**. Under NSQF the learner can acquire the Certification for Competency needed at any level through formal, non-formal or informal learning.

The **Workshop Calculation & Science - Aeronautical Structure and Equipment Fitter 2<sup>nd</sup> Year NSQF (Revised 2022)** under CTS is one of the book developed by the core group members as per the NSQF syllabus.

The **Workshop Calculation & Science - Aeronautical Structure and Equipment Fitter 2<sup>nd</sup> Year NSQF (Revised 2022)** under CTS as per NSQF is the outcome of the collective efforts of experts from Field Institutes of DGT, Champion ITI's for each of the Sectors, and also Media Development Committee (**MDC**) members and Staff of **NIMI**. NIMI wishes that the above material will fulfill to satisfy the long needs of the trainees and instructors and shall help the trainees for their Employability in Vocational Training.

NIMI would like to take this opportunity to convey sincere thanks to all the Members and Media Development Committee (MDC) members.

Chennai - 600 032

EXECUTIVE DIRECTOR

## ACKNOWLEDGEMENT

The National Instructional Media Institute (NIMI) sincerely acknowledge with thanks the co-operation and contribution of the following Media Developers to bring this IMP for **Workshop Calculation & Science - Aeronautical Structure and Equipment Fitter 2<sup>nd</sup> Year** as per NSQF Revised 2022.

### MEDIA DEVELOPMENT COMMITTEE MEMBERS

Shri. M. Sangara pandian	-	Training Officer (Retd.) CTI, Govt. of India, Guindy, Chennai - 32.
Shri. G. Sathiamoorthy	-	Jr. Training Officer - SG (Retd.) Govt. I.T.I., Trichy, DET - Tamilnadu.
Smt. S. Meenakshi	-	Assistant Training Officer, Govt. I.T.I., Guindy, DET - Tamilnadu.
Smt. M.V. Vijayavalli	-	Assistant Training Officer, Govt. I.T.I., Ambattur, DET - Tamilnadu.

### NIMI CO-ORDINATORS

Shri. Nirmalya Nath	-	Deputy General Manager, NIMI, Chennai - 32.
Shri. G. Michael Johny	-	Manager, NIMI, Chennai - 32.

NIMI records its appreciation of the **Data Entry, CAD, DTP Operators** for their excellent and devoted services in the process of development of this IMP.

NIMI also acknowledges with thanks, the efforts rendered by all other staff who have contributed for the development of this book.

## INTRODUCTION

The material has been divided into independent learning units, each consisting of a summary of the topic and an assignment part. The summary explains in a clear and easily understandable fashion the essence of the mathematical and scientific principles. This must not be treated as a replacement for the instructor's explanatory information to be imparted to the trainees in the classroom, which certainly will be more elaborate. The book should enable the trainees in grasping the essentials from the elaboration made by the instructor and will help them to solve independently the assignments of the respective chapters. It will also help them to solve the various problems, they may come across on the shop floor while doing their practical exercises.

The assignments are presented through 'Graphics' to ensure communications amongst the trainees. It also assists the trainees to determine the right approach to solve the problems. The required relevant data to solve the problems are provided adjacent to the graphics either by means of symbols or by means of words. The description of the symbols indicated in the problems has its reference in the relevant summaries.

At the end of the exercise wherever necessary assignments, problems are included for further practice.

### Time allotment - 2<sup>nd</sup> Year : 22 Hrs

Time allotment for each title of exercises has been given below. **Workshop Calculation & Science - Aeronautical Structure and Equipment Fitter 2<sup>nd</sup> Year NSQF Revised Syllabus 2022.**

S.No	Title	Exercise No.	Time in Hrs
1	Friction	2.1.01 - 2.1.03	6
2	Centre of Gravity	2.2.04	4
3	Area of cut out regular surfaces and area of irregular surfaces	2.3.05	4
4	Elasticity	2.4.06 & 2.4.07	2
5	Estimation and Costing	2.5.08 & 2.5.09	6
		<b>Total</b>	<b><u>22 Hrs</u></b>

## LEARNING / ASSESSABLE OUTCOME

On completion of this book you shall be able to

- **Demonstrate basic mathematical concept and principles to perform practical operations.**
- **Understand and explain basic science in the field of study.**

## CONTENTS

Exercise No.	Title of the Exercise	Page No.
	<b>Friction</b>	
2.1.01	Friction - Advantages and disadvantages, Laws of friction, co-efficient of friction, angle of friction, simple problems related to friction	1
2.1.02	Friction - Lubrication	9
2.1.03	Friction - Co- efficient of friction, application and effects of friction in workshop practice	12
	<b>Centre of Gravity</b>	
2.2.04	Centre of gravity - Centre of gravity and its practical application	14
	<b>Area of cut-out regular surfaces and area of irregular surfaces</b>	
2.3.05	Area of cut-out regular surfaces - circle, segment and sector of circle	23
	<b>Elasticity</b>	
2.4.06	Elasticity - Elastic, plastic materials, stress, strain and their units and young's modulus	26
2.4.07	Elasticity - Ultimate stress and working stress	38
	<b>Estimation and Costing</b>	
2.5.08	Estimation and costing - Simple estimation of the requirement of material etc., as applicable to the trade	41
2.5.09	Estimation and costing - Problems on estimation and costing	47

# SYLLABUS

2<sup>nd</sup> Year

**Workshop Calculation & Science - Aeronautical Structure and Equipment Fitter**  
**Revised syllabus July 2022 under CTS**

S.no.	Syllabus	Time in Hrs
I	<b>Friction</b> 1 Advantages and disadvantages, Laws of friction, co- efficient of friction, angle of friction, simple problems related to friction 2 Friction – Lubrication 3 Co- efficient of friction, application and effects of friction in workshop practice	6
II	<b>Centre of Gravity</b> 1 Centre of gravity and its practical application	4
III	<b>Area of cut out regular surfaces and area of irregular surfaces</b> 1 Area of cut out regular surfaces – circle, segment and sector of circle	4
IV	<b>Elasticity</b> 1 Elastic, plastic materials, stress, strain and their units and young's modulus 2 Ultimate stress and working stress	2
V	<b>Estimation and Costing</b> 1 Simple estimation of the requirement of material etc., as applicable to the trade 2 Problems on estimation and costing	6
	<b>Total</b>	<b>22</b>



**Friction - Advantages and disadvantages, Laws of friction, co-efficient of friction, angle of friction, simple problems related to friction**

**Introduction**

When on a solid surface, another solid is rubbed a force is created between the two solids which acts in the opposite direction of motion or tries to obstruct the motion of the object, this force is called frictional force. This phenomenon is called friction. This happens due to roughness of the two surfaces.

In other words, It is the force of resistance offered to motion, experienced by bodies which are in contact. It depends upon the normal reaction between the contacting surfaces and the nature of the surfaces. No surface is absolutely friction less.

Friction plays an important role in our daily life. It would not be possible to walk without friction between our foot and floor. Vehicles are able to run on roads because of the friction between the wheels and road.

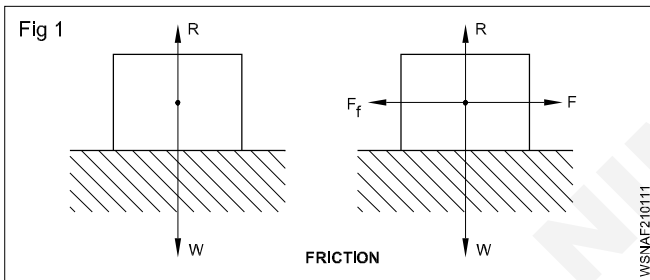

**Types of friction**

- 1 Static friction
- 2 Dynamic friction

**1 Static friction**

The friction between two solid objects when at rest is called static friction.

Eg. Static friction can prevent an object from sliding down on a sloped surface.

**Limiting friction**

When the frictional force (F) is equal to the applied pulling force (P) then the friction between two surfaces is known as limiting friction. (i.e  $F=P$ )

**2 Dynamic friction**

It is the friction between two objects, when are in motion is called dynamic friction. It is also called kinetic friction.

**Sliding friction**

It is the friction experienced by an object when its slides over another object. Sliding friction is always less than limiting friction.

**Rolling friction**

It is the friction that occurs when a circular object such as a ball or roller rolls on a flat surface. Rolling friction is less than sliding friction. (ball or roller bearing)

**Forces acting on a body when a pulling force is applied to move (Fig 2)**

- Weight of the block acting vertically downward (W)
- The normal reaction which acts upwards (R)
- The applied pulling force (F)
- The frictional force ( $F_f$ )

When the body is about to move  $W=R, F=P$

When pulling force is increased the body starts to move.

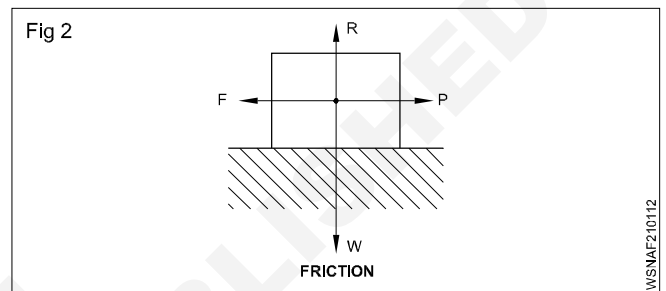

**Advantages of friction**

- 1 Helps us to walk without slipping.
- 2 Used to stop vehicles when brakes are applied.
- 3 Movement of vehicles due to friction between revolving wheels with tyres and the road.
- 4 Power transmission using gear drive or belt pulley drive.
- 5 Using friction we can sharp any object and also to hold it.
- 6 Nails and screws are held in wood by friction.
- 7 Heat is produced when two rough surfaces are rubbed against each other.

**Disadvantages of friction**

- 1 It causes wear and tear of the machine parts.
- 2 It produces heat and may cause melting of machine parts. To avoid production of heat using of coolant is necessary.
- 3 It reduces efficiency of a machine.
- 4 It reduces speed of the moving object. eg. spindle, shaft, piston etc.

**Friction can be reduced**

- 1 By using suitable lubricants (oil, grease) between the moving parts.
- 2 By polishing the surface to make them smooth.
- 3 By using ball bearings and roller bearings.
- 4 By the use of wheel.

### Laws of friction (Fig 3 & 4)

- Frictional force is directly proportional to the normal reaction between contacting surfaces.
- Frictional force acts opposite to the direction of motion.
- Frictional force depends on the nature of contacting surfaces.
- Frictional force is independent over the area and shape of contacting surfaces.

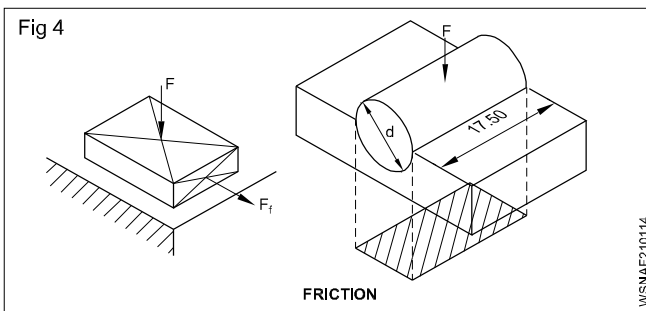
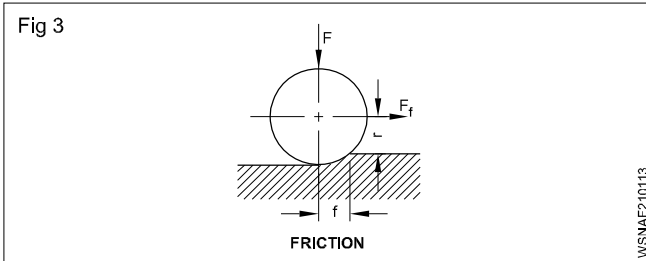

### Coefficient of friction

The ratio between the limiting friction force and the normal reactions is called the co-efficient of friction.

Suppose, by applying a force P kg, the object is just fit to move, then limiting friction force will be produced in between the two surfaces. The limiting friction force will be equal to external force applied and will work in the opposite direction.

$$\therefore F = P \text{ kg}$$

According to the second law of limiting friction force, the friction force will be proportional to normal reaction.

$$F \propto R \quad (\propto \text{ sign is proportional to})$$

$$F = R \times \text{constant}$$

or 
$$\frac{F}{R} = \text{constant}$$

This constant between objects is called Co-efficient of Friction. This is represented by  $\mu$ .

$$\mu = \frac{F}{R} \text{ or } F = \mu.R$$

$$\text{Co-efficient of Friction} = \frac{\text{Limiting friction force}}{\text{Normal reaction}}$$

Co-efficient of friction is always constant for any two objects and it has no units.

### Angle of friction (Fig 5)

The forces acting on a body when it is just about to move by the application of a pulling force are W, R, P and F. The forces 'R' and 'F' are compounded and we get the resultant force 'S'. The angle formed by 'S' with 'R' is the angle of friction.

Therefore

$$\tan \theta = \frac{F}{W}$$

$$\tan \theta = \mu$$

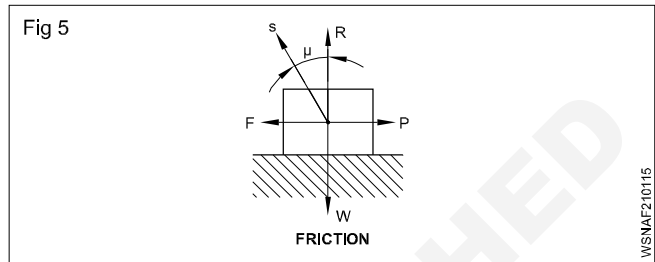

### Angle of repose (Fig 6)

A body placed on an inclined surface remains at rest till the angle of inclination equals the angle of friction. When it exceeds the body starts sliding down. This is known as angle of repose.

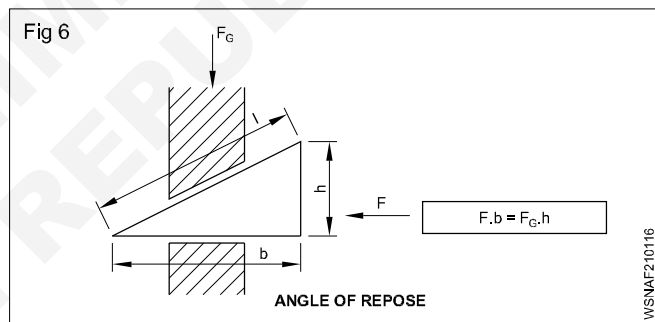

### Inclined Plane (Fig 7)

According to the figure, given below plane AB is inclined  $\theta^\circ$  to the horizontal. On this, the vertical line working at W kg weight will make an angle with normal line of the inclined plane equal to the degree of inclination of the base at the horizontal.

The first component of weight 'W' of the object acts on the normal line and is equal to  $W \cos \theta^\circ$ . The second component acts parallel to base and downward and is equal to  $W \sin \theta^\circ$ .

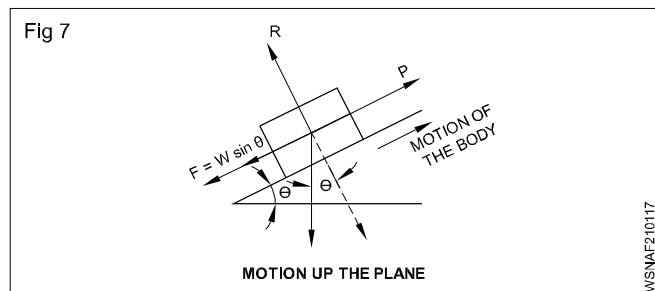

$$\therefore \text{Normal Reaction 'R'} = W \cos \theta^\circ$$

$$\text{Limiting Friction Force 'F'} = W \sin \theta^\circ$$

$$\therefore \text{Co-efficient of friction '}\mu\text{'} = \frac{F}{R}$$

$$= \frac{W \sin \theta}{W \cos \theta}$$

$$= \tan \theta$$

$$\therefore \mu = \tan \theta$$

It may also be mentioned as:

In an inclined plane, some object without any external force applied only due to  $W \sin \theta$  is about to come right downwards, then the plane makes an angle equal to the angle of friction with the horizontal.

### Force of Friction When the Force is Horizontal (Fig 8)

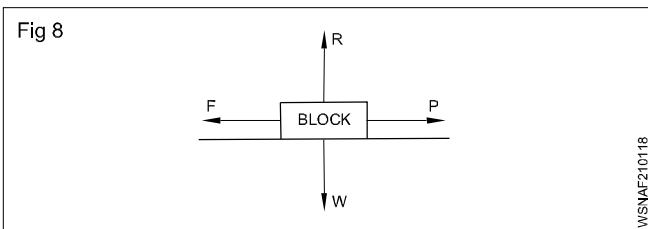

Let,

$P$  = Force required to pull the block

$F$  = Force of friction

$R$  = Normal reaction

$W$  = Weight of block

$\mu$  = Co-efficient of friction between block and surface.

As per observation from the figure 8:

The block will move forward, if it has been overcome by the force of friction.

$$\therefore P = F \text{ (it is horizontal)}$$

Normal reaction of block is opposite to the direction of weight.  $\therefore R = W$

$$\therefore \text{Force of friction} = \mu \cdot R$$

$$\therefore \text{Force required to move the block} = \mu \cdot R$$

### Force of Friction When the Force is Inclined at an Angle $\theta$ with the Horizontal (Fig 9)

Let,

$\theta$  = Angle of pull 'P' to move the block with the horizontal

$W$  = Weight of block

$R$  = Normal reaction

$P$  = Pull at an angle ' $\theta$ ' with the horizontal

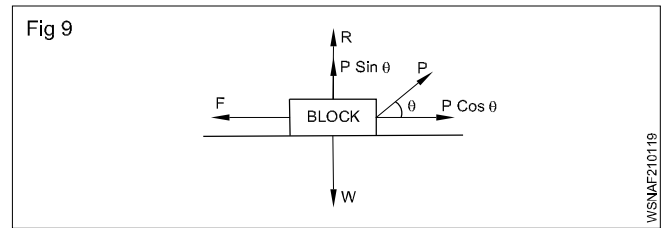

As per observations: from the geometry of figure 9, it is obvious:

$$\text{Horizontal component of 'P'} = P \cos \theta$$

$$\text{Vertical component of 'P'} = P \sin \theta$$

The horizontal component  $P \cos \theta$  will be the effective pull, while the vertical component  $P \sin \theta$  will go on for reducing the normal reaction.

As per condition of equilibrium :

Algebraic sum of horizontal components = 0

$$F - P \cos \theta = 0$$

$$F = P \cos \theta$$

Algebraic sum of vertical components = 0

$$R + P \sin \theta - W = 0$$

$$R = W - P \sin \theta$$

We know

$$F = \mu \cdot R$$

$$P \cos \theta = \mu [W - P \cdot \sin \theta]$$

$$= \mu \cdot W - \mu \cdot P \cdot \sin \theta$$

$$P \cos \theta = \mu \cdot W + \mu \cdot P \cdot \sin \theta = 0$$

$$P [\cos \theta + \mu \cdot \sin \theta] = \mu \cdot W$$

$$P = \frac{\mu \cdot W}{\cos \theta + \mu \cdot \sin \theta}$$

Force of pull required at an angle of  $\theta$  with the horizontal is given by:

$$P = \frac{\mu \cdot W}{\cos \theta + \mu \cdot \sin \theta}$$

### Example

1 A force of 40 kg is required to pull a weight of 400 kg on a horizontal plane. Determine the coefficient of friction.

$$\text{Coefficient of friction} = \frac{\text{Force}}{\text{Weight}} = \frac{F}{W}$$

But  $F = P$  and  $R = W$

$$\mu = \frac{F}{W} = \frac{F_f}{R} = \frac{40}{400}$$

$$\mu = 0.1$$

- 2 A force of 30 N is required to move a body of mass 35 kg on a flat surface horizontally at a constant velocity. Find the coefficient of friction.

Mass of the body = 35 kg. = W (By taking

The weight force =  $35 \times 10 = 350 \text{ N}$  1 kg = 10 N)

(By taking  $g = 10 \text{ metre/sec}^2$ )

$$\mu = \frac{F}{W} = \frac{F_f}{R} = \frac{30}{350} = \frac{3}{35} = 0.086$$

$$\mu = 0.09$$

- 3 A solid weighs 20 kg. This is placed on a solid surface. How much force does it require to come in motion when co-efficient of friction is 0.24.

Co-efficient of friction ( $\mu$ ) = 0.24

Weight (W) = 20 kg

Force required (F) = ?

$$\mu = \frac{F}{W}$$

$$0.24 = \frac{F}{20}$$

$$F = 20 \times 0.24$$

$$F = 4.8 \text{ kg}$$

- 4 A tanker with loaded weight of 14500 kg is running on the road. If the co-efficient friction between tyres and road surface is 0.28. Find out its force of friction.

Co-efficient of friction ( $\mu$ ) = 0.28

Weight (W) = 14500 kg

Force friction (F) = ?

$$\mu = \frac{F}{W}$$

$$0.28 = \frac{F}{14500}$$

$$F = 0.28 \times 14500$$

$$F = 4060 \text{ kg.}$$

- 5 A force of 800 gram weight is needed to pull a block weighing 3200 gram. What is the co-efficient of friction.

Force (F) = 800 gm

Weight (W) = 3200 gm

Co-efficient of friction ( $\mu$ ) = ?

$$\text{Co-efficient of friction } (\mu) = \frac{F}{W}$$

$$= \frac{800}{3200}$$

$$\mu = 0.25$$

- 6 A force of 40 kg is required to move a mass of 80 kg on a flat surface horizontally at a constant velocity. Calculate its co-efficient of friction?

Force (F) = 40 kg

Weight (W) = 80 kg

Co-efficient of friction ( $\mu$ ) = ?

$$\text{Co-efficient of friction } (\mu) = \frac{F}{W}$$

$$\mu = \frac{40}{80}$$

$$\mu = 0.5$$

- 7 A weight of 10 kg is resting on a horizontal table and can just moved by a force of 2 kg. Find the co-efficient of friction?

Weight (W) = 10 kg

Force (F) = 2 kg

Co-efficient of friction ( $\mu$ ) = ?

$$\text{Co-efficient of friction } (\mu) = \frac{F}{W}$$

$$= \frac{2}{10}$$

$$\mu = 0.2$$

- 8 A body weighing 100 kg is resting on a table. Find the co-efficient of friction if a force of 30 kg makes its just to move?

Weight (W) = 100 kg

Force (F) = 30 kg

Co-efficient of friction ( $\mu$ ) = ?

$$\text{Co-efficient of friction } (\mu) = \frac{F}{W}$$

$$= \frac{30}{100}$$

$$\mu = 0.3$$

- 9 A metal block weighing 10 kg rests on a horizontal table. A horizontal force of 2.5 kg can just slide the block. Find the normal reaction, limiting friction and co-efficient of friction?

Weight (W) = 10 kg

Force (F) = 2.5 kg

R = ?

Normal reaction = W

Limiting friction = ?

$\mu$  = ?

Normal reaction (R) = 10 kg

Limiting friction (F) = 2.5 kg

$$\mu = \frac{F}{W}$$
$$= \frac{2.5}{10}$$
$$\mu = 0.25$$

**10 A wooden block weights 100 kg. If the co-efficient of friction is 0.3, find out force required to move the block.**

Weight (W) = 10 kg

Co-efficient of friction ( $\mu$ ) = 0.3

Force (F) = ?

$$\mu = \frac{F}{W}$$
$$0.3 = \frac{F}{100}$$
$$F = 100 \times 0.3$$
$$F = 30 \text{ kg}$$

**11 Calculate the angle of inclination, if a weight of 150 kg is in equilibrium, co-efficient of friction is 0.25. Calculate the force of normal reaction also.**

Work done (W) = 150 kg

Co-efficient of friction ( $\mu$ ) = 0.25

$\theta$  = ?

Force F = ?

$$\mu = \tan \theta = 0.25$$
$$= 14^\circ 2' 20''$$
$$\mu = \frac{F}{W}$$
$$0.25 = \frac{F}{150}$$
$$F = 0.25 \times 150$$
$$F = 37.5 \text{ Kg.}$$

**12 A body of mass 60kg rests on a horizontal plane. The value of co-efficient of friction between it and the plane being 0.2. Find the work done in moving the body through a distance of 5 meters along the plane.**

Co-efficient of friction ( $\mu$ ) = 0.2

Weight (W) = 60 kg

Distance (S) = 5 m

Work done (W) = ?

$$\mu = \frac{F}{W}$$

$$0.2 = \frac{F}{60}$$

$$F = 60 \times 0.2$$
$$= 12 \text{ kg}$$

Work done = Force x distance = F x S

$$= 12 \times 5$$

$$= 60 \text{ Kg.m}$$

**(ie) Work done (or) Applied force = 60 Kg.m**

**13 If a force of 30N is required to move a mass of 35kg on a flat surface horizontally at constant velocity, what will be the co-efficient of friction?**

Force (F) = 30 N

Weight (W) = 35 kg

1 kg = 9.8 N

$$35 \text{ Kg} = 9.8 \times 35 = 343 \text{ N}$$

$$\text{Co-efficient of friction} = \mu = \frac{F}{W}$$

$$= \frac{30 \text{ N}}{35 \text{ kg}}$$

$$= \frac{30 \text{ N}}{35 \times 9.8 \text{ N}}$$

$$\mu = 0.087$$

**14 A block of ice weighing one quintal rests in equilibrium on a wooden plank inclined at 30°. Find the coefficient of friction between the ice and wood.**

W = 1 quintal = 100 kg = Weight

$$\theta = 30^\circ \quad \frac{F}{W} = \mu = \tan \theta$$

$$\mu = \tan \theta = \tan 30^\circ$$

$$\mu = 0.5774$$

**15 Calculate the force that is required to slide a mass of 980 kg on a guide, when the coefficient of friction between the surfaces is 0.09.**

Weight (W) = 980 kg

Co-efficient of friction ( $\mu$ ) = 0.09

Force (F) = ?

$$\text{Co-efficient of friction} = \mu = \frac{F}{W}$$

$$0.09 = \frac{F}{980 \text{ kg}}$$

$$F = 0.09 \times 980 \text{ kg}$$

$$\text{Required force(F)} = 88.2 \text{ kg}$$

**16 A metal block weighing 10kg rests on a horizontal board and the coefficient of friction between the surfaces is 0.22. Find (a) the horizontal force which will just move the block and (b) the force acting at an angle of 30° with the horizontal, which will just move the block.**

$$\text{Weight (W)} = 10 \text{ kg}$$

$$\text{Co-efficient of friction } (\mu) = 0.22$$

(a)  $F = ?$

(b) Force acting at an angle of 30° with the horizontal?

(a) 
$$\mu = \frac{F}{W}$$

$$0.22 = \frac{F}{10 \text{ kg}}$$

$$F = 2.2 \text{ Kg.}$$

(b) Force acting at an angle of 30° =  $\frac{F}{\cos \theta}$

$$= \frac{2.2}{\cos 30^\circ}$$

$$= \frac{2.2}{0.8660}$$

$$\text{Force acting at an angle of } 30^\circ = \mathbf{2.54 \text{ kg}}$$

**17 Calculate the angle of inclination, if a weight of 250 kg is in equilibrium. Coefficient of friction is 0.36. Calculate the force of normal reaction also.**

$$\text{Angle of inclination } (\theta) = ?$$

$$\text{Weight (W)} = 250 \text{ kg}$$

$$\mu = 0.36$$

$$\text{Force (F)} = ?$$

$$\tan \theta = \mu$$

$$\tan \theta = 0.36$$

$$\theta = 19^\circ 48'$$

$$\mu = \frac{F}{W}$$

$$0.36 = \frac{F}{250 \text{ kg}}$$

$$F = 0.36 \times 250 \text{ kg}$$

$$F = \mathbf{90 \text{ kg.}}$$

**18 A body of mass 10 kg rests on a horizontal plane. The co-efficient of friction between the body and plane is 0.15. Find the work done in moving the body through a distance of 10 metre.**

$$\text{Weight (W)} = 10 \text{ kg}$$

$$\text{Co-efficient of friction } (\mu) = 0.15$$

$$\text{Distance (S)} = 10 \text{ metre}$$

$$\text{Work done (W)} = ?$$

$$\mu = \frac{F}{W}$$

$$0.15 = \frac{F}{10 \text{ Kg}}$$

$$F = 0.15 \times 10 \text{ kg}$$

$$F = 1.5 \text{ kg}$$

$$\text{Work done} = W = F \times S$$

$$= 1.5 \text{ kg} \times 10 \text{ m}$$

$$\text{Work done} = \mathbf{15 \text{ kg.m}}$$

## Assignment A

- 1 A force 50N is required to move a mass of 40kg on a flat surface horizontally at a constant velocity. Find the coefficient of friction. (9.8N = 1kg)
- 2 A vehicle having a weight of 800kg is moving on the road. If the coefficient of friction between the tyres and road surface is 0.3, then calculate the force of friction.
- 3 A solid weighing 50kg is placed on a solid surface. How much force is required to move the block when coefficient of friction is 0.25 between the block and the surface.
- 4 A railway wagon weighs 1250 tonnes. If the coefficient of friction between it and the rails is 0.003, find the force required to move the wagon.
- 5 A body of mass 100kg rests on a horizontal plane. The angle of friction between the body and the plane being 0.025. Find the work done in moving the body through a distance of 16m along the plane.
- 6 A body of mass 20kg rests on a horizontal plane, the co-efficient of friction between the body and plane is 0.3. Find the work done in moving the body through a distance of 10 metres.
- 7 A body of mass 2000 kg moves a distance of 10 meters in 5 sec. If the co-efficient of friction between the body and floor is 0.3 find the horizontal force required to move the body and horsepower absorbed against friction.

- 8 A vehicle is moving at 50kmph and the load on the vehicle is 5000 kg. Find the H.P. required to move the vehicle if  $\mu = 0.2$ .
- 9 Find out the power lost due to friction by a planer under the following conditions.  
Mass of the planer table = 3500 kg

Rate of movement of the table = 0.5 m/sec

Co-efficient of friction between the table and the ways = 0.06

- 10 A truck having weight 12000 kg is moving on the road. If the co-efficient of friction between the tyres and the road surface is 0.3, then calculate the force of friction.

## Assignment B

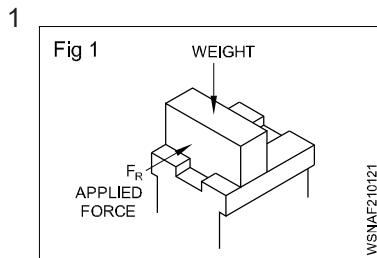

$F = 1800 \text{ N}$   
 $\mu$  (static) = 0.16  
 $\mu$  (dynamic) = 0.012  
 $F_R$  to overcome static friction = \_\_\_\_\_ N  
 $F_R$  to overcome dynamic friction = \_\_\_\_\_ N

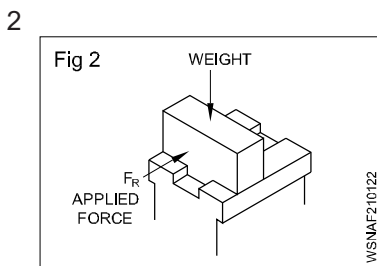

mass = 250 kg  
 $F_R = 160 \text{ N}$   
 $\mu =$  \_\_\_\_\_

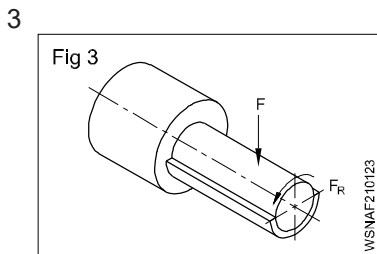

$F = 5000 \text{ N}$   
 $\mu$  (dry) = 0.03  
 $\mu$  (fluid friction) = 0.01  
 $F_R$  when dry = \_\_\_\_\_ N  
 $F_R$  when lubricated = \_\_\_\_\_ N

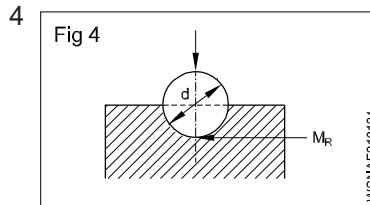

$F = 1.2 \text{ kN}$   
 $d = 60 \text{ mm}$   
 $\mu = 0.03$   
 Frictional torque  $M_R =$  \_\_\_\_\_ Nm  
 (Frictional torque = Frictional force x radius)

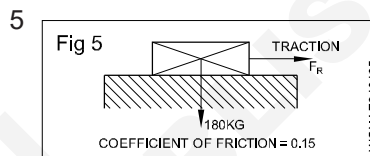

mass = 180 kg  
 $\mu = 0.15$   
 $F_R =$  \_\_\_\_\_ N

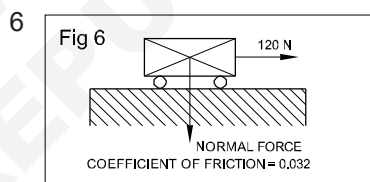

$F_R = 120 \text{ N}$   
 $\mu = 0.032$   
 Normal force  $F =$  \_\_\_\_\_ N

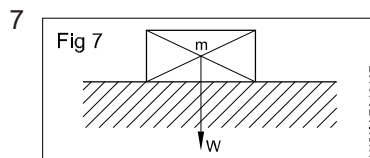

$m = 1000 \text{ kg}$   
 $\mu = 0.4$   
 Force required to move  $F_R =$  \_\_\_\_\_ N

## C MCQ

- 1 Which one of the following is useful friction  
 A Rings in cylinders      B Crankshaft bearings  
 C Brake shoe linings      D Wheel hole bearings
- 2 Which is in between the wheels and road, if vehicles are able to run on roads.  
 A erosion                      B motion  
 C corrosion                    D friction
- 3 Which direction of motion frictional force acts.  
 A equal                          B opposite  
 C inclined                       D forward
- 4 What is the formula of angle of friction, if 'F' is the frictional force, R is the normal reaction and  $\theta$  is the angle of friction.  
 A  $\tan \theta = \frac{F}{R}$                       B  $\cot \theta = \frac{F}{R}$   
 C  $\sin \theta = \frac{F}{R}$                       D  $\cos \theta = \frac{F}{R}$

5 What is the formula for Co-efficient of friction (m).

A  $\mu = \frac{R}{F}$

B  $\mu = \frac{F}{R}$

C  $\mu = F \times R$

D  $\mu = F + R$

6 A loaded truck weighs 2400 kg and it can be moved by a force of 30 kg. Determine the co-efficient of rolling friction

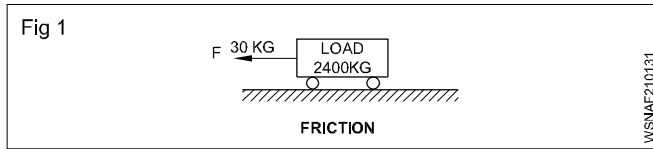

A 0.0215

B 0.0152

C 0.0125

D 0.0251

7 Calculate the pulling force required for the figure shown.

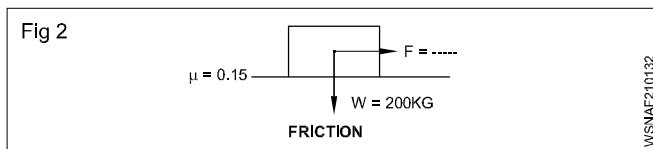

A 27 Kg

B 28 Kg

C 29 Kg

D 30 Kg

8 Determine the co-efficient of friction ( $\mu$ ) between brass and steel when a brass slider was placed on the horizontal steel surface until it is just moving, if brass slides (W) = 3 Kgf and required force is 0.7 Kgf.

Brass slides (W) = 3 Kgf

Force (F) required = 0.7 kgf

A 0.033

B 0.133

C 0.233

D 0.333

9 Which is necessary to avoid production of heat.

A sand

B coolant

C lubricant

D salt

10 Which is used to reduce the friction.

A lubricants

B sand

C coal

D coolant



**Friction - Lubrication**

There are 3 systems of lubrication.

- Gravity feed system
- Force feed system
- Splash feed system

**Gravity feed**

The gravity feed principle is employed in oil holes, oil cups and wick feed lubricators provided on the machines. (Figs 1 & 2)

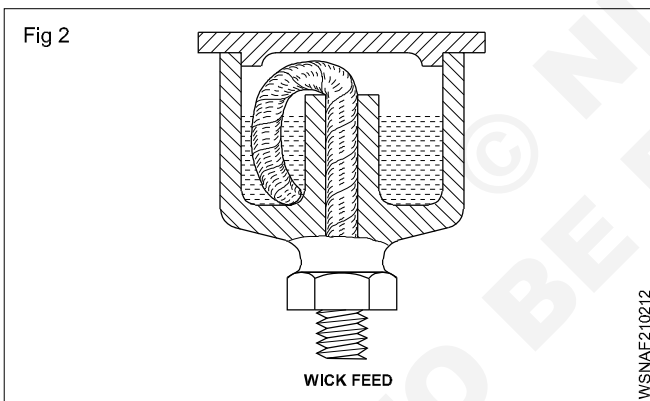
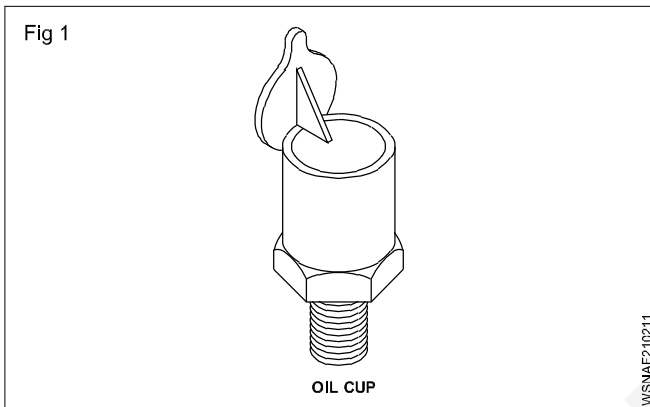

**Force feed/Pressure feed**

**Oil, grease gun and grease cups**

The oil hole or grease point leading to each bearing is fitted with a nipple, and by pressing the nose of the gun against this, the lubricant is forced to the bearing. Greases are also force fed using grease cup. (Fig 3)

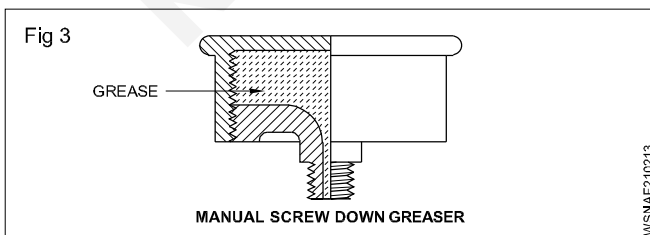

Oil is also pressure fed by hand pump and a charge of oil is delivered to each bearing at intervals once or twice a day by operating a lever provided with some machines. (Fig 4) This is also known as shot lubricator.

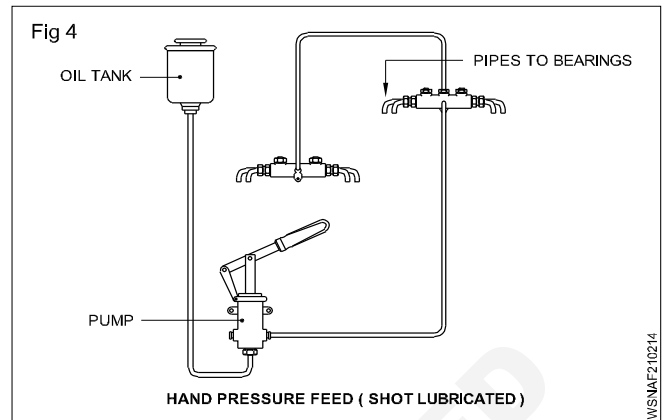

**Oil pump method**

In this method an oil pump driven by the machine delivers oil to the bearings continuously, and the oil afterwards drains from the bearings to a sump from which it is drawn by the pump again for lubrication.

**Splash lubrication**

In this method a ring oiler is attached to the shaft and it dips into the oil and a stream of lubricant continuously splashes around the parts, as the shaft rotates. The rotation of the shaft causes the ring to turn and the oil adhering to it is brought up and fed into the bearing, and the oil is then led back into the reservoir. (Fig 5) This is also known as ring oiling.

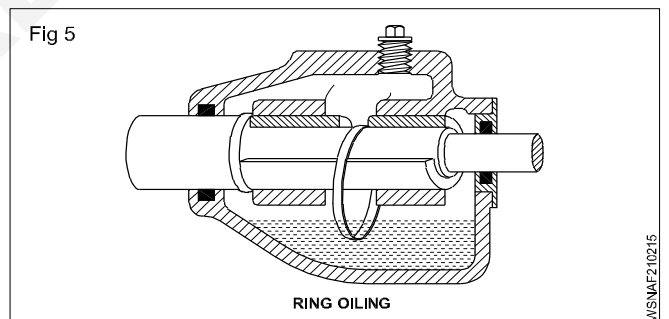

In other systems one of the rotating elements comes in contact with that of the oil level and splash the whole system with lubricating oil while working. (Fig 6) Such systems can be found in the headstock of a lathe machine and oil engine cylinder.

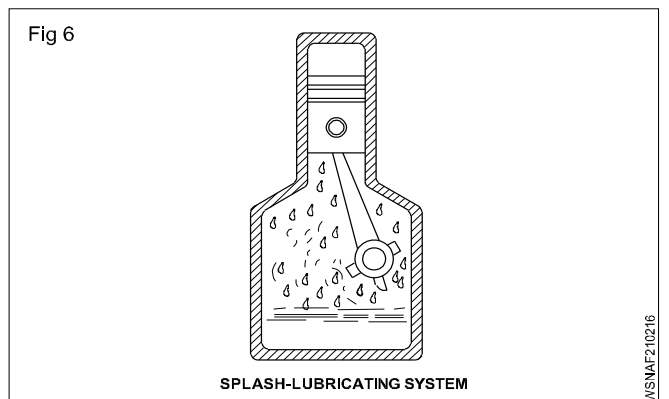

WSNAF210214

WSNAF210211

WSNAF210212

WSNAF210213

WSNAF210215

WSNAF210216

## Types of grease guns

The following types of grease guns are used for lubricating machines.

- 'T' handle pressure gun (Fig 7)

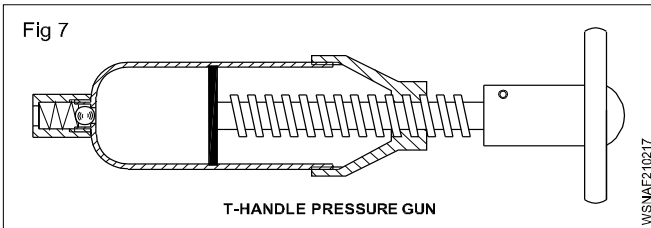

- Automatic and hydraulic type pressure gun (Fig 8)

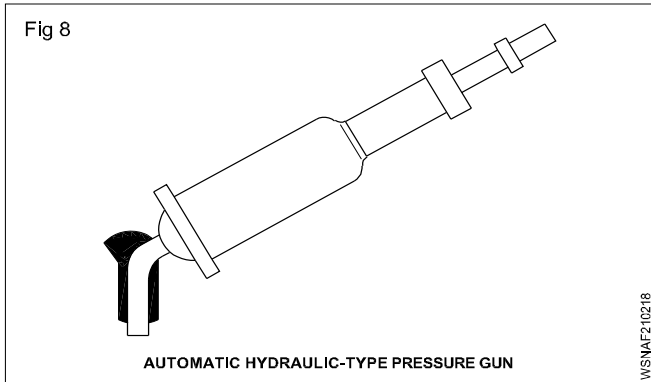

- Lever-type pressure gun (Fig 9)

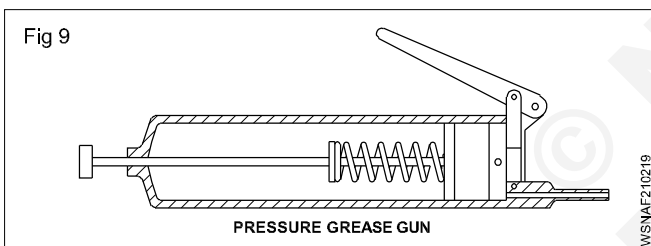

## Lubrication to exposed slideways

The moving parts experience some kind of resistance even when the surface of the parts seems to be very smooth.

The resistance is caused by irregularities which cannot be detected by the naked eyes.

Without a lubricant the irregularities grip each other as shown in the diagram. (Fig 10)

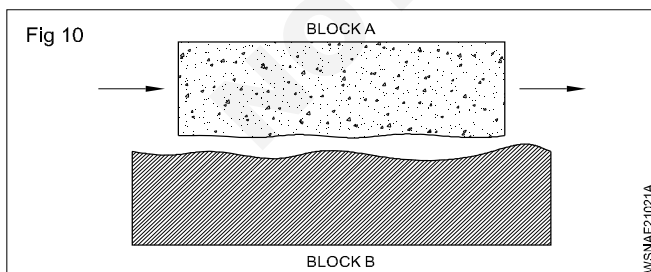

With a lubricant the gap between the irregularities fills up and a film of lubricant is formed in between the mating components which eases the movement. (Fig 11)

The slideways are lubricated frequently by an oilcan. (Fig 12)

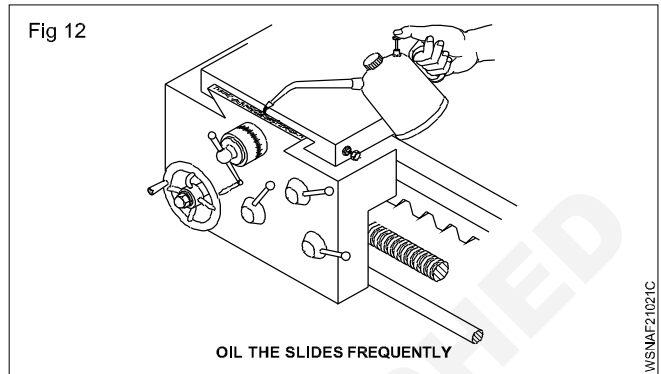
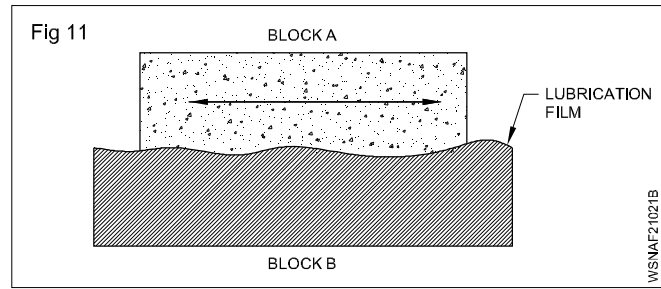

After cleaning the open gears, oil them and repeat lubrication regularly. (Fig 13)

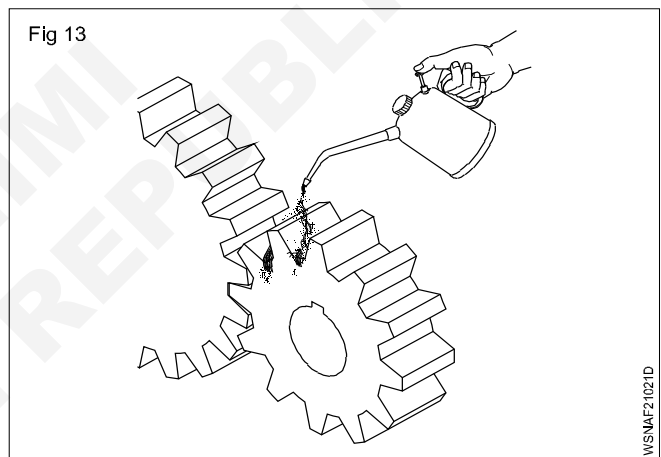

## Lubricate bearings

A shaft moving in a bearing is also subjected to frictional resistance. The shaft rotates in a bush bearing or in ball/roller bearing, experiencing friction.

When the shaft is at rest on the bottom of the bush bearing, there is hardly any lubricant between the shaft and the bush. (Fig 14)

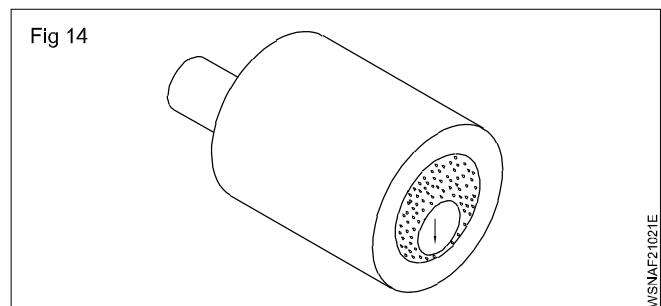

When the shaft starts rotating the lubricant maintains a film between the shaft and the bush and an uneven ring of lubricant builds up. (Fig 15)

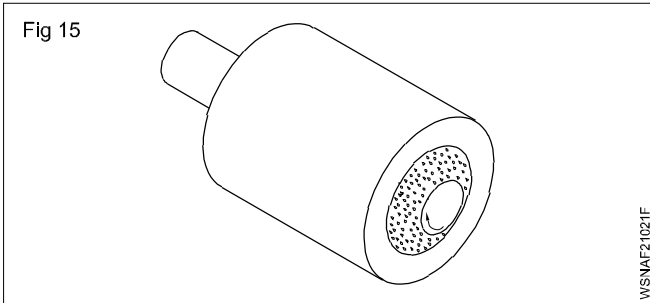

When the shaft is rotating at full speed a full ring of lubricating film surrounds the shaft (Fig 16) which is known as hydro dynamic lubrication.

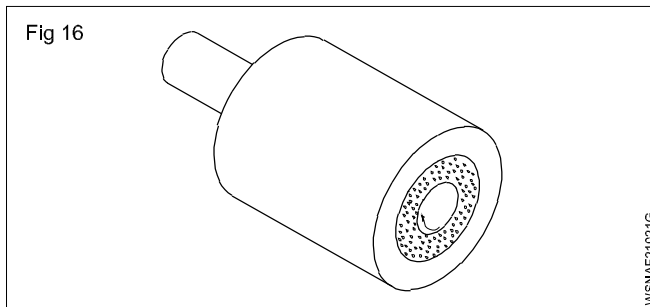

This lubrication ring decreases the frictional resistance very much and at the same time protects the mating members against wear and changes.

Some bush bearings have oil feeding holes over which the oil or grease cup is mounted and the lubricant is fed through the holes into the bearing by gravity feed system.(Fig 17)

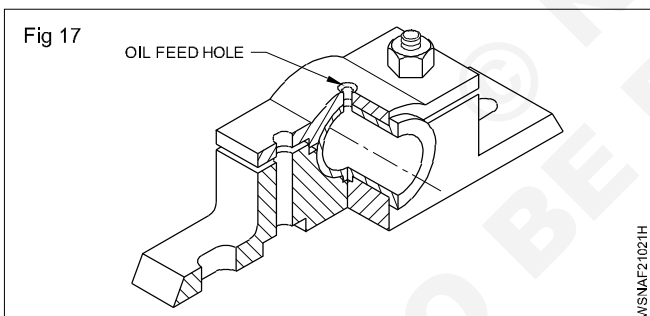

### Hints for lubricating machines:

- identify the oiling and greasing points
- select the right lubricants and lubricating devices
- apply the lubricants.

The manufacturer's manual contains all the necessary details for lubrication of parts in machine tools. Lubricants are to be applied daily, weekly, monthly or at regular intervals at different points or parts as stipulated in the manufacturer's manual.

These places are indicated in the maintenance manuals with symbols as shown in Fig 18.

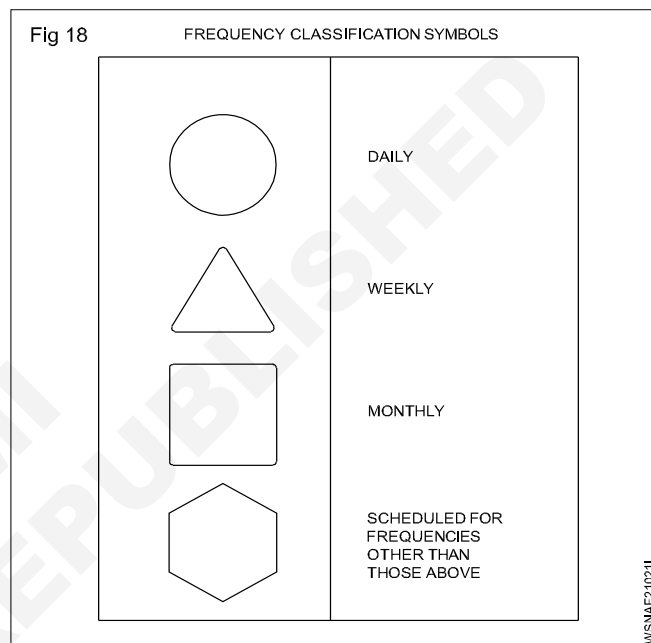

## Friction - Co-efficient of friction, application and effects of friction in workshop practice

### Co-efficient of friction

The ratio between the limiting frictional force and the normal reaction is called co-efficient of friction.

Suppose, by applying a force 'P' kg, the object is just fit to move, then limiting frictional force will be produced in between the two surfaces. The limiting frictional force will be equal to external force applied and will work in the opposite direction.

$$\therefore F = P \text{ kg}$$

According to the second law of limiting frictional force, the frictional force will be proportional to normal reaction.

$$F \propto R \text{ (}\propto\text{ sign is proportional to)}$$

$$F = R \times \text{constant}$$

$$\text{or } \frac{F}{R} = \text{constant}$$

This constant between objects is called co-efficient of friction. This is represented by  $\mu$ .

$$\mu = \frac{F}{R} \text{ or } F = \mu R$$

$$\text{Co-efficient of friction} = \frac{\text{Limiting frictional force}}{\text{Normal reaction}}$$

Co-efficient of friction is always constant for any two objects and it has no unit.

### Example

- 1 The sliding valve of a steam engine has dimensions 25cm by 45 cm and the steam pressure on the back of the valve is 25 kg/cm<sup>2</sup>. If the co-efficient of friction is 0.13. Calculate the force required to move the valve?

Dimension of steam valve = 25 cm x 45 cm.

Steam pressure = 25 kg/cm<sup>2</sup>

Co-efficient of friction = 0.13

Force required to move the valve = ?

$$F = ?$$

Force of the steam = Pressure x Area

$$= 25 \times 25 \times 45$$

$$\frac{25\text{kg}}{\text{cm}^2} \times 25\text{cm} \times 45\text{cm} = 28125 \text{ kg.}$$

Force acts on the valve = 28125 kg

$$\mu = \frac{F}{W}$$

$$0.13 = \frac{F}{28125}$$

$$F = 0.13 \times 28125$$

Force required to move the valves = 3656.25 Kg

- 2 An empty drum weighing 50kg is resting on a shop floor. Find the coefficient of friction if a force of 15kg makes it just move.

Weight (W) = 50 kg

Force (F) = 15

$$\text{Co-efficient of friction } \mu = \frac{F}{W}$$

$$= \frac{15 \text{ kg}}{50 \text{ kg}}$$

$$\mu = 0.3$$

- 3 A machine crate weighing 1000kg moves distance of 5m in 5 sec. If the coefficient of friction between the crate and floor is 0.3, calculate the horizontal force required to move the crate and horse power absorbed against friction.

Weight (W) = 1000 kg

Distance (S) = 5 meter

Time (t) = 5 second

i) Co-efficient of friction ( $\mu$ ) = 0.3

ii) Force (F) = ?

Horse power (H.P.) = ?

$$\text{i) } \mu = \frac{F}{W}$$

$$0.3 = \frac{F}{1000 \text{ Kg}}$$

$$F = 0.3 \times 1000 \text{ kg}$$

$$F = 300 \text{ kg}$$

$$(1 \text{ HP} = 75 \text{ m.kg/sec})$$

$$\text{ii) } \text{H.P.} = \frac{F \times S}{t} \times \frac{1}{75}$$

$$\text{H.P} = \frac{300 \times 5}{5} \times \frac{1}{75} = 4 \text{ H.P}$$

Horse power absorbed against friction = 4.H.P.

- 4 A weight of 600 kg is kept on the inclined plane at 30°. Calculate the normal reaction and force rolling downwards.

Solution:

Weight kept on the inclined plane (W) = 600kg

Angle of the inclined plane ( $\theta$ ) = 30°

$$\begin{aligned} \therefore \text{Normal reaction (R)} &= W \cdot \cos \theta \\ &= 600 \times \cos 30^\circ \\ &= 600 (0.8660) \\ &= 519.6 \text{ kg} \end{aligned}$$

$$\begin{aligned} \text{Force rolling downwards} &= W \cdot \sin \theta \\ &= 600 \times \sin 30^\circ \\ &= 600 (0.5000) \\ &= 300 \text{ kg} \end{aligned}$$

$\therefore$  Normal reaction = 519.6 kg

Force rolling downwards = 300 kg

- 5 Find out the power lost due to friction by a planer under the following conditions.

Mass of the planer table = 3500 kg

Rate of movement of the table = 0.5m/sec

Co-efficient of friction between the table and the ways } = 0.06

Solution:

Weight of planer (W) = 3500 kg

Distance moved (d) = 0.5 m/sec

Co-efficient of friction ( $\mu$ ) = 0.06

$$\text{Co-efficient of friction} = \mu = \frac{F}{W}$$

$$0.06 = \frac{F}{3500}$$

$$F = 0.06 \times 3500 = 210 \text{ kg}$$

Workdone = F x distance moved

$$= 210 \times 0.5 = 105 \text{ kgm/sec}$$

$$75 \text{ kgm/sec} = 1 \text{ H.P}$$

$$105 \text{ kgm/sec} = \frac{105 \times 1}{75} = 1.4 \text{ H.P}$$

Power lost due to friction = 1.4 H.P

- 6 A planer table weighing 800 kg moves a distance of 2 metres in seconds on its bed. If co-efficient of friction between bed and table is 0.30 find the power required to move the table against the friction.
- 7 On a milling machine table a component of 20 kgf is clamped with the help of three equidistant clamps. What force must be exerted by each clamp to avoid slipping of the component when the horizontal cutting force is 60 kgf and the coefficient of friction is equal to 0.2.
- 8 A machine weight of 14500 kg moving on the floor. If the co-efficient of friction between the machine and floor surface is 0.28 then calculate the force of friction.
- 9 A tail stock of a lathe has a mass of 21.5 kg and co-efficient of friction at the slides is 0.122. What horizontal force will be required to slide the tail stock?
- 10 An inclined surface makes an angle of 30 degrees with the horizontal. An object weighting 5 tons is placed on the surface. Find out the normal reaction at the object and also the effective force required to bring the object downwards.

Centre of gravity - Centre of gravity and its practical application

Any object comprises of a large number of particles. Each particle is pulled towards the earth due to the force of gravity. Thus, the forces on the particles are equal, parallel and act in the same direction. These forces will have a resultant which acts through a particular point 'G'. This fixed point 'G' is called the centre of gravity. (Fig 1)

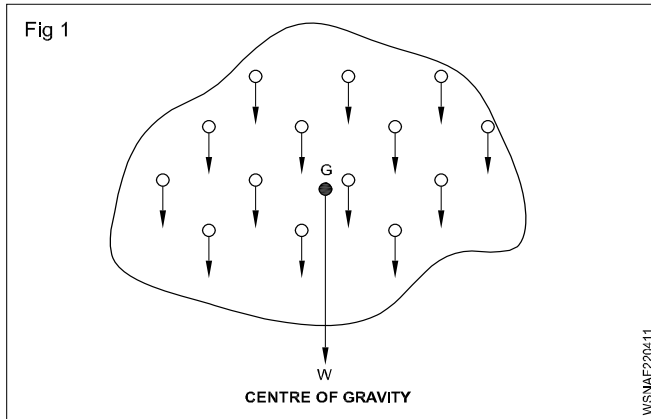

Concept of Centre of gravity (Fig 2)

In physics, an imaginary point in a body of matter where, for convenience in certain calculations, the total weight of the body may be thought to be concentrated. The concept is sometimes useful in designing static structures (e.g., buildings and bridges) or in predicting the behaviour of a moving body when it is acted on by gravity.

In a uniform gravitational field the centre of gravity is identical to the centre of mass, a term preferred by physicists.

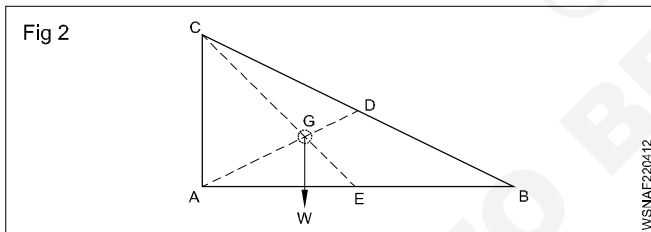

Gravitation

The mutual attractive force of bodies due to which they attract each other is called gravitation.

1 Gravity

The attractive force of the earth due to which it attracts all bodies towards its centre is called gravity.

The value of gravity varies from place to place on the ground surface. Its general value is 9.81 m/s<sup>2</sup>.

Centroid

Different geometrical shapes such as the circle, triangle and rectangle are plane figures having only 2-dimensions. They are also known as laminas. They have only area, but no mass. The centre of gravity of these plane figures is called as the Centroid. It is also known as the geometrical centre. The method of finding out the centroid of a plane figure is the same as that of finding out the centre of gravity of a body. If the lamina is assumed to have uniform mass

per unit area, then the centroid is also the centre of gravity in a uniform gravitational field.

Methods to calculate centre of gravity

- 1 By geometrical consideration.
- 2 By moments.

**Principle :** The total moment of a weight about any axis = The sum of the moments of the various parts about the same axis.

- 3 By graphical method.

The first two methods are generally used to find out the centre of gravity or centroid, as the third method can become tedious.

Centre of gravity by geometrical consideration (Fig 3)

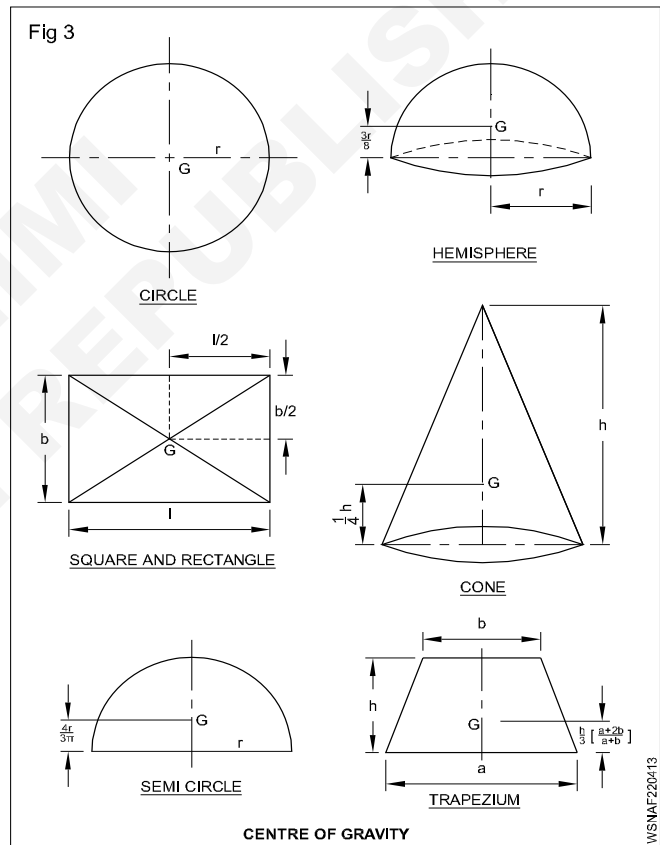

- 1 The centre of gravity of a circle is its centre.
- 2 The centre of gravity of a square, rectangle or a parallelogram is at the points where its diagonals meet each other. It is also the middle point of the length as well as the width.
- 3 The centre of gravity of a triangle is at the point where the medians of the triangle meet.
- 4 The centre of gravity of a right circular Cone is at a  $\frac{1}{4}h$  distance of from its base.

- 5 The centre of gravity of a hemisphere is at a distance  $\frac{3r}{8}$  of from its base.
- 6 The centre of gravity of a semicircle is at a perpendicular distance of  $\frac{4r}{3\pi}$  from its centre.
- 7 The centre of gravity of a trapezium with parallel side 'a' and 'b' is at a distance of  $\frac{h}{3} \left( \frac{a+2b}{a+b} \right)$  measured from the base 'a'.
- 8 The centre of gravity of a cube of side 'L' is at equal distance from every face.
- 9 The centre of gravity of a Sphere of diameter 'd' is at a distance of  $\frac{1}{2}d$  from every point (or) sphere centre.

### Centre of gravity; An experiment

- Number of pencil = 2
- A fine edge like a ruler or a credit card
- A permanent marker
- A ruler

#### Step 1

Attempt to balance the pencil on the edge you have selected

Balancing the pencil may take some trial and error. The point at which the pencil balances may not be where you first thought. If it begins to tip in one direction, move the pencil back slowly in the opposite direction until it will stay there on its own.

#### Step 2

Once the pencil is balanced, mark the location of the balancing point with a permanent marker.

#### Step 3

Measure the distance between the ends of the pencil and the balancing point you have marked. Are the two lengths equal? On my pencil, the length from the eraser to the balancing point was actually 1.25 inches less than the length from the pencil tip to the balancing point. Why would this be the case?

In our experiment, the balancing point was another word for the centre of gravity of this pencil. In other words, if we cut the pencil in two at the mark we made in the experiment, the two parts would be equal in weight. However, they are not equal in length. As you may have already figured out, the metal piece that houses the eraser contributes more to the weight of the pencil, so the CG is closer to that side of the pencil.

### Keeping up with that centre (Fig 4)

The centre of gravity is an important concept in determining the stability of a structure. It's the reason why a good homeowner will keep the top branches of his trees trimmed. It's also the reason why a pick-up truck might not be the

best vehicle choice for a first time driver. Stability is maximized in objects with a lower centre of gravity and a wide base. The taller and more top-heavy an object, the more likely it is to tip over when it is tilted by a force. This figure demonstrates a bus driving on two different grades; the second one is steep enough to cause the centre of gravity to fall outside of the base of the vehicle, which will cause it to topple over.

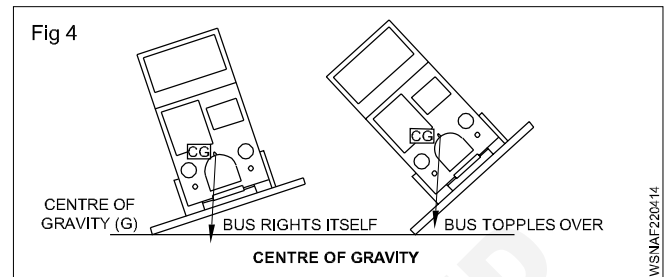

### Equilibrium

A body is said to be in equilibrium if the resultant of all the forces acting on a body is zero and if there is no turning moment.

There are three states of equilibrium (Fig 5)

- 1 Stable equilibrium
- 2 Unstable equilibrium
- 3 Neutral equilibrium

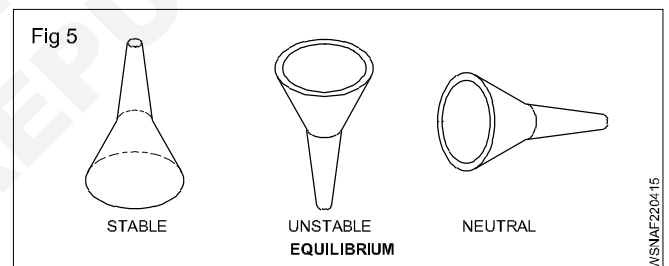

#### 1 Stable equilibrium

A body is said to be in a stable equilibrium if it returns to its original position when slightly displaced. (The C.G. is as low as possible).

- E.g :
- 1 A cone resting on its base (Fig 6)
  - 2 A ball on a concave surface
  - 3 Funnel resting on its base.

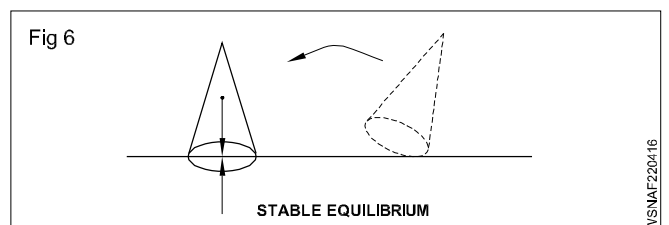

#### 2 Unstable equilibrium

A body is said to be in an unstable equilibrium if it does not return to its original position when slightly displaced. Its centre of gravity falls taking it away from its original position. (CG is at high points)

- E.g:
- 1 A cone resting on its tip (Fig 7)
  - 2 A ball on convex surface
  - 3 Funnel standing on its tube end.

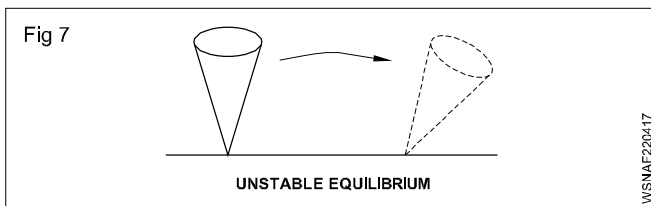

### 3 Neutral equilibrium

A body is said to be in a neutral equilibrium if on being slightly displaced, it takes a new position similar to its original one. The centre of gravity remains undisturbed. (CG is neither raised or lowered)

- Eg:
- 1 A cone resting on its side (Fig 8)
  - 2 A ball on flat surface
  - 3 Funnel resting on its side

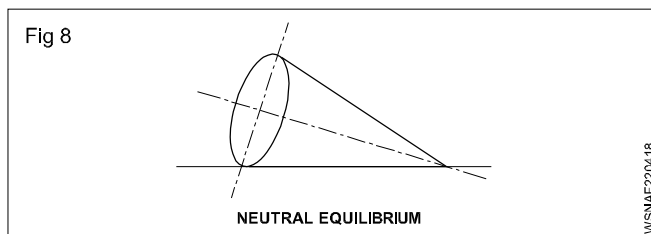

### Model 1

Conditions for stable equilibrium

- The CG should be as low as possible.
- It should have a broad base.
- The vertical line passing through the CG should fall within the base.

### Conditions of equilibrium

A body is said to be in a state of equilibrium under the action of forces when there is no motion of rotation or translation of the body. There are three conditions of equilibrium of a body which are given below:

- i Algebraic sum of the horizontal components of all the forces acting on the body must be zero.

$$\Sigma H = 0$$

- ii Algebraic sum of the vertical components of all the forces acting on the body must be zero.

$$\Sigma V = 0$$

- iii Algebraic sum of the moments of all the forces acting on the body must be zero.

$$\Sigma M = 0$$

**Torque or twisting moment of a couple is given by the product of force applied and the arm of the couple (i.e. Radius). In fact, moment means the product of "force applied" and the "perpendicular distance of the point and the line of the force".**

### Some example of equilibrium in daily life

- 1 The lower decks of the ships are loaded with heavy cargoes. This makes the centre of gravity of the whole ship lower and its equilibrium becomes more stable.
- 2 A man carrying a bucket full of water in one hand extends his opposite arm and bends his body towards it.
- 3 While carrying load on back the man bends forward so that his and the load's centre of gravity falls on his feet, if he walks erect, he will fall backward.
- 4 While climbing a mountain, a man bends forward and bends backward while descending so that the centre of gravity of his load falls on his feet.
- 5 In a double-decker, more passengers are accommodated in the lower deck and less on the upper so that the centre of gravity of the bus and the passengers is kept low to eliminate any chance of tilting.

### Example

- 1 Find the centroid of the isosceles triangular plate as shown in the figure.

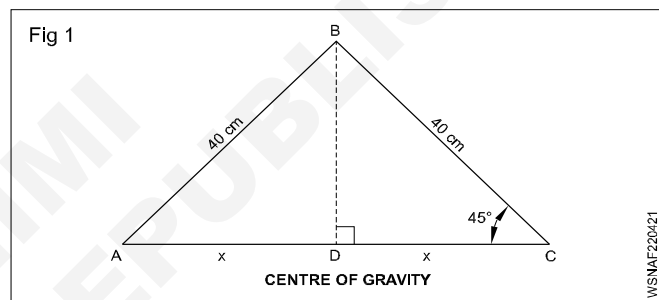

Since  $\angle BCD = 45^\circ$  then  $BD = DC = x$

As per Pythagoras theorem

$$BD^2 + DC^2 = CB^2$$

$$x^2 + x^2 = 40^2$$

$$2x^2 = 1600$$

$$x^2 = \frac{1600}{2} = 800$$

$$x = \sqrt{800} = 28.28 \text{ cm}$$

$$\text{Centroid from DB} = \frac{x}{3} = \frac{28.28}{3} = 9.43 \text{ cm}$$

- 2 A rectangular lamina has 10 cm and 8 cm. Find the centroid. (Centroid of rectangular = Diagonals intersecting point.)

Centroid of rectangular = Diagonals intersecting point

$$\text{Centre of AB} = \frac{10}{2} = 5$$

$$\text{Centre of AD} = \frac{8}{2} = 4$$

Centroid lying 4 cm from AB and 5 cm from AD



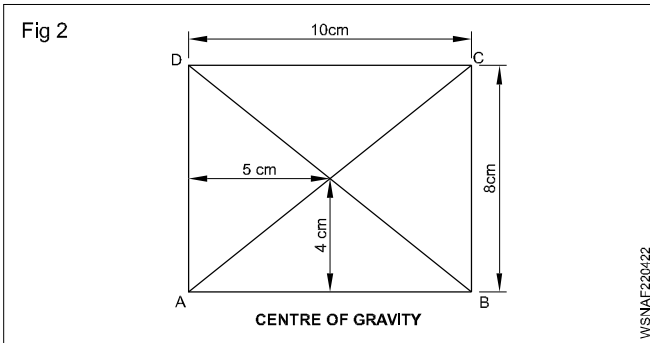

3 A thin lamina is shown in the figure below. Find the centre of gravity.

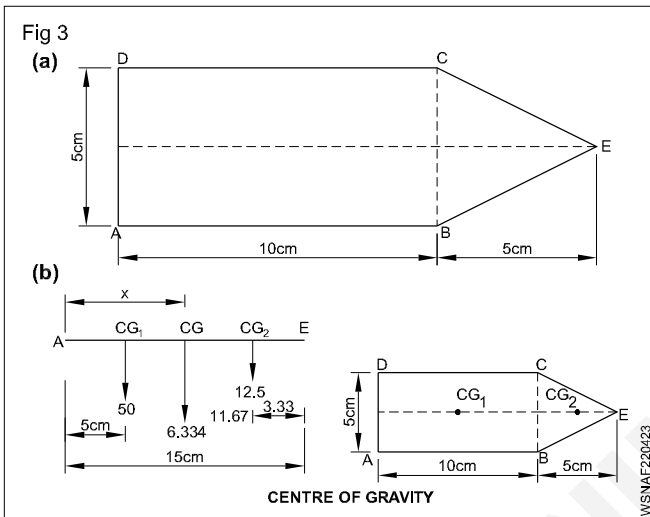

Centroid of rectangle

$$\text{Area of rectangle} = 5 \times 10 = 50 \text{ cm}^2$$

$$\begin{aligned} \text{Area of triangle} &= \frac{1}{2} bh \\ &= \frac{1}{2} \times 5 \times 5 = 12.5 \text{ cm}^2 \end{aligned}$$

$$\text{Total area} = 50 + 12.5 = 62.5 \text{ cm}^2$$

The centre of gravity for rectangle is the point of intersection of diagonal = 5 cm distance from AD ( $CG_1$ )

Centre of gravity for triangle is  $\frac{1}{3}$  distance from its height.

$$= 5 \times \frac{1}{3} = \frac{5}{3} = 1.67 \text{ cm}$$

( $CG_2$ ) Centroid of plate is lying in between  $CG_1$  and  $CG_2$ . From the figure torque is about AD.

$$\begin{aligned} 62.5x &= 50 \times 5 + 12.5 \times 11.67 \\ &= 250 + 145.875 \end{aligned}$$

$$62.5x = 395.875$$

$$x = \frac{395.875}{62.5} = 6.334 \text{ cm}$$

Centre of gravity is 6.334 cm from AD, on the centre axis.

4 A thin lamina consists of an isosceles triangle of height 120mm and base 100mm placed on a semicircle of diameter 100mm. find the location of its centre of gravity.

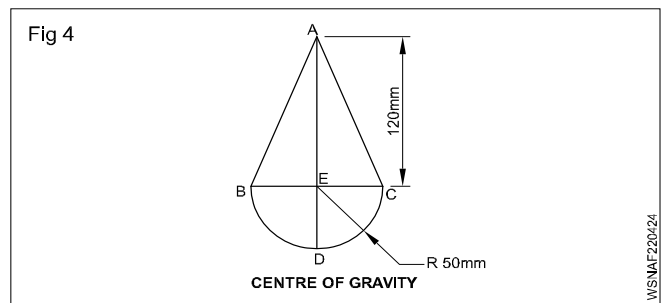

$$\begin{aligned} \text{Area of right angled triangle } (a_1) &= \frac{1}{2} bh \\ &= \frac{1}{2} \times 10 \times 12 \\ &= 60 \text{ cm}^2 \end{aligned}$$

$$\begin{aligned} \text{Centroid of right angled triangle} &= \frac{1}{3} h \text{ from base} \\ &= \frac{1}{3} \times 12 \\ \text{Centroid from E} &= 4 \text{ cm} \end{aligned}$$

$$\begin{aligned} \text{Centroid from A } (h_1) &= 12 - 4 = 8 \text{ cm} \end{aligned}$$

$$\begin{aligned} \text{Area of half circle } (a_2) &= \frac{1}{2} \pi r^2 \\ &= \frac{1}{2} \times 3.14 \times 5 \times 5 \\ &= 39.25 \text{ cm}^2 \end{aligned}$$

Centroid of semi circle = (Vertical distance from centre of diagonal)

$$= \frac{4r}{3\pi}$$

$$\begin{aligned} \text{Centroid distance from E to D} &= \frac{4 \times 5}{3 \times 3.14} \\ &= 2.123 \text{ cm} \end{aligned}$$

$$\begin{aligned} (h_2) &= \left( \begin{array}{l} \text{Height of} \\ \text{triangle} \end{array} \right) + \left( \begin{array}{l} \text{Centroid of} \\ \text{half circle} \end{array} \right) \\ &= 12 + 2.123 \\ &= 14.123 \text{ cm} \end{aligned}$$

To find centroid of lamina

$$y = \frac{a_1 h_1 + a_2 h_2}{a_1 + a_2}$$

$$= \frac{60 \times 8 + 39.25 \times 14.123}{60 + 39.25}$$

$$= \frac{480 + 554.328}{99.25}$$

$$= \frac{1034.328}{99.25}$$

$$= 10.421 \text{ cm}$$

Centroid is lying at 10.421 cm from point A

- 5 A uniform rod weighing 50kg and 3m long carries loads as shown below. Find out the distance of the CG of the system from the left hand end.

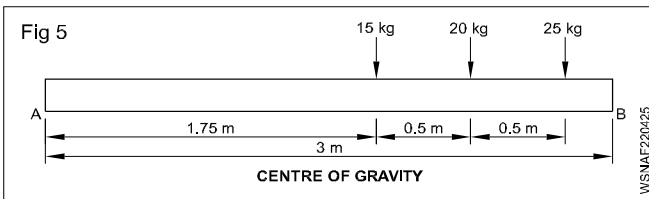

Distance of CG from A =  $x$

Total weight = 50 + 15 + 20 + 25 = 110 kg

$$110x = (50 \times 1.5) + (15 \times 1.75) + (20 \times 2.25) + (25 \times 2.75)$$

$$= 75 + 26.25 + 45 + 68.75 = 215$$

$$\text{Therefore } x = \frac{215}{110} = 1.96 \text{ m}$$

Distance of CG of the system from A = 1.95 m

- 6 A long shaft is composed of two section A and B each 3 meter long and weight 36KN and 20KN respectively. Find out the position of centre of gravity of the shaft.

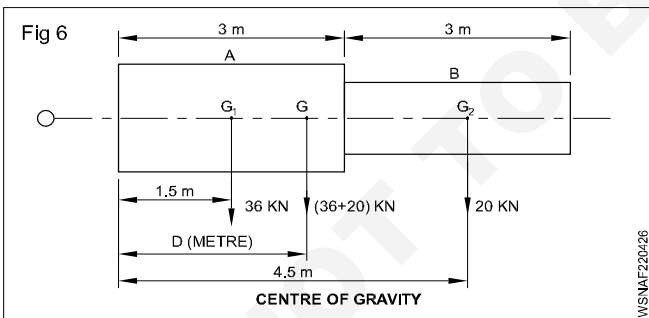

### Solution

Let  $G_1$  be the c.g. point of section A

Let  $G_2$  be the common c.g. of the shaft and its distance is D from left hand end.

Now, take moments about 'O'

A Moment of section A about O = 36 kN x 1.5 m

Moment of section B about O = 20 kN x 4.5 m

Adding both we get as below

Total moment about O = (36 kN x 1.5 m + (20 kN x 4.5 m)

$$= 54 \text{ kNm} + 90 \text{ kNm}$$

$$= 144 \text{ kNm}$$

- B This moment is equal to moment of section A and section B about 'O' (distance of action being D metre)

That is = (36 kN + 20 kN) x D (metre) = 56 kNm

Again equating A and B

$$144 \text{ kNm} = 56 \text{ kNm}$$

$$\frac{144 \text{ kNm}}{56 \text{ kNm}} = D$$

$$\frac{144}{56} = D$$

$$\text{Therefore } D = \frac{18}{7}$$

$$= 2.57 \text{ metres}$$

The distance of CG of the shaft from left hand is 2.57 metres.

- 7 A thin lamina is shown in the figure. Find centre of gravity.

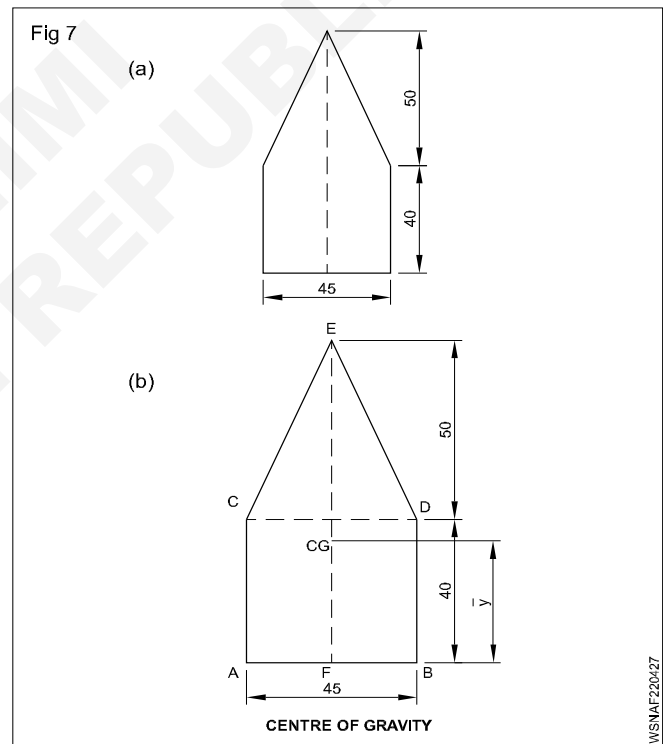

As the body is symmetrical about y-axis centre of gravity lies on this axis.

Let AB is the axis of reference

Let  $y$  = The distance between centre of gravity and point F, the point of reference as shown in the figure.

Let  $a_1$  = Area of rectangle CDBA = 45 x 40 = 1800 mm<sup>2</sup>

$h_1$  = Distance between centre of gravity of rectangle of

$$\text{point F} = \frac{40}{2} = 20 \text{ mm}$$

Let  $a_2$  = Area of triangle ECD =  $\frac{1}{2} \times \text{base} \times \text{height}$   
 $= \frac{1}{2} \times 45 \times 50 = 1125$  square mm

$h_2$  = distance between centre of gravity of triangle of point F.

$= \frac{1}{3}$ rd height of triangle + width of rectangle

$$= \frac{1}{3}(50) + 40 = \frac{50}{3} + 40 = \frac{170}{3} \text{ mm}$$

Applying formula

$$y = \frac{a_1 h_1 + a_2 h_2}{a_1 + a_2}$$

$$= \frac{1800(20) + 1125\left(\frac{170}{3}\right)}{1800 + 1125}$$

$$= \frac{36000 + 63753.75}{2925} = \frac{99753.75}{2925}$$

$$y = 34.10 \text{ mm}$$

**The CG is at a distance of 34.1mm from point F the point of reference in the line AB.**

### 8 Find the CG of the lamina shown below.

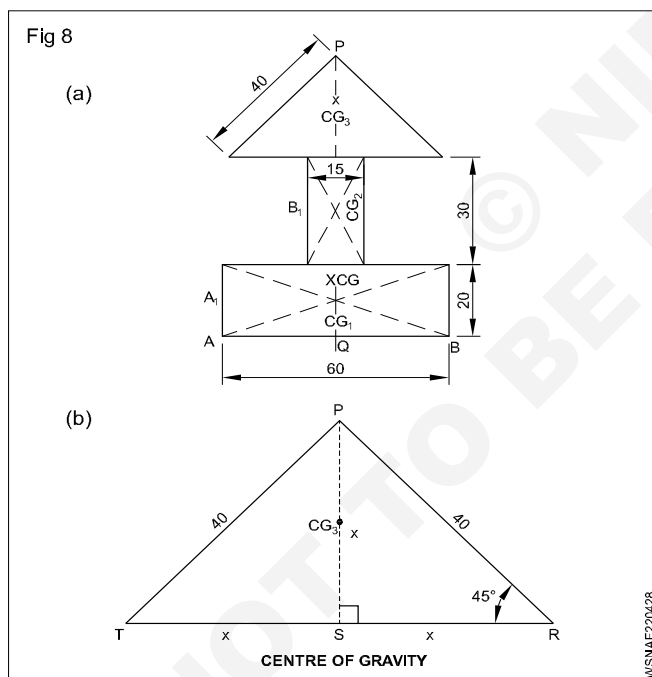

CG is in PQ

$CG_1, CG_2$  and  $CG_3$  - centres of centre of gravity.

$$\begin{aligned} \text{Area of } A_1 &= 60 \times 20 \text{ mm}^2 \\ &= 1200 \text{ mm}^2 \end{aligned}$$

$$\begin{aligned} \text{Distance of } CG_1, \text{ from AB} &= \frac{20}{2} \text{ mm} \\ &= 10 \text{ mm} \end{aligned}$$

$$\begin{aligned} \text{Area of } B_1 &= 30 \times 15 \text{ mm}^2 \\ &= 450 \text{ mm}^2 \end{aligned}$$

$$\begin{aligned} \text{Distance of } CG_2 \text{ from AB} &= 20 + \frac{30}{2} \text{ mm} \\ &= 20 + 15 \text{ mm} \\ &= 35 \text{ mm} \end{aligned}$$

$\Delta PTR$  - Isosceles triangle

Draw perpendicular line PS on TR from P.

$\Delta PSR$  - right angled triangle

By applying Pythagoras theorem,

$$x^2 + x^2 = 40^2$$

$$2x^2 = 1600$$

$$x^2 = 800$$

$$x = \sqrt{800}$$

$$= 28.28 \text{ mm}$$

$$\text{Area of triangle} = \frac{1}{2} \times b \times h \text{ mm}^2$$

$$= \frac{1}{2} \times 56.56 \times 28.28 \text{ mm}^2$$

$$= 800 \text{ mm}^2$$

$$\text{Distance of } CG_3 \text{ from TR} = \frac{x}{3} = \frac{28.28}{3} \text{ mm} = 9.43 \text{ mm}$$

$$\text{Dist. Of } CG_3 \text{ from AB} = 20 + 30 + 9.43 \text{ mm} = 59.43 \text{ mm}$$

$$\text{Total area} = 1200 + 450 + 800 \text{ mm}^2 = 2450 \text{ mm}^2$$

Distance from AB = Ymm

$$\text{Taking moment at AB } 2450 y = 1200 \times 10 + 450 \times 35 + 800 \times 59.43$$

$$= 12000 + 15750 + 47544$$

$$= 75294$$

$$y = \frac{75294}{2450} = 30.73 \text{ mm}$$

**Distance of CG is on the line PQ from side AB = 30.73 mm.**

### 9 A steel square rod 100x12x12cm has a hole dia 6cm drilled in it as shown in the figure. Find the position of the C.G. of the square rod.

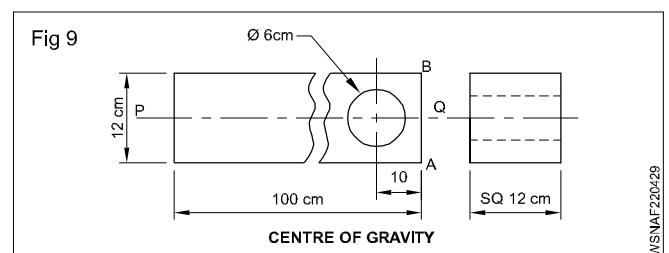

$$\text{Volume of rod} = a^2 h \text{ unit}^3$$

$$= 12 \times 12 \times 100 \text{ cm}^3$$

$$= 14400 \text{ cm}^3$$

$$\begin{aligned} \text{Volume of circle} &= \pi r^2 h \text{ unit}^3 \\ &= \pi \times 3 \times 3 \times 12 \text{ cm}^3 \\ &= 339.3 \text{ cm}^3 \\ \text{Remaining volume} &= 14400 - 339.8 \text{ cm}^3 \\ &= 14060.7 \text{ cm}^3 \end{aligned}$$

C.G is on PQ

$$\begin{aligned} \text{CG in before drilling} &= C.G_1 \\ \text{CG in before drilling} &= C.G_2 \\ \text{CG in after drilling} &= C.G \end{aligned}$$

Calculating the moment on side AB

$$\text{Distance of } CG_1 = \frac{100}{2} = 50 \text{ cm}$$

$$\text{Distance of } CG_2 = 10 \text{ cm}$$

$$\text{Distance of C.G} = x$$

$$14060.7 \times x + 339.3 \times 10 = 14400 \times 50$$

$$14060.7x + 3393 = 720000$$

$$14060.7x = 720000 - 3393$$

$$= 716607$$

$$x = \frac{716607}{14060.7}$$

$$= 50.97 \text{ cm}$$

C.G. of the square rod = 50.97 cm from side AB.

### 10 Centre of gravity in a lamina (Area)

Find the position of c.g of the area shown in Fig10.  
(All dimensions are in mm.)

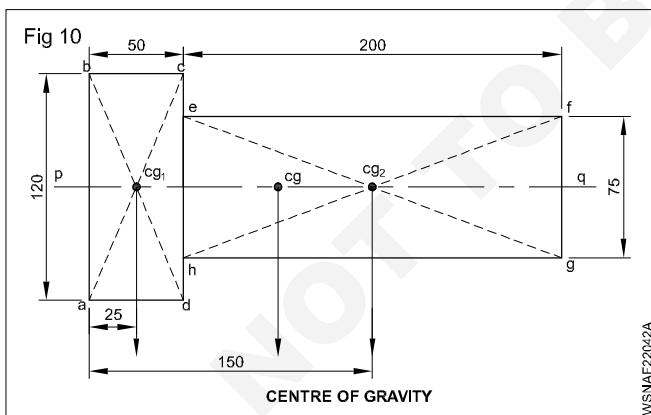

### Solution

Taking moments of area about the line **ab**, we get the equation as below.

Moment of area **abcd**+moment of area **efgh**=moment of area of complete figure.

Now to calculate the areas

$$\begin{aligned} 1 \text{ Area of } abcd &= 120 \text{ mm} \times 50 \text{ mm} \\ &= 6000 \text{ mm}^2 \end{aligned}$$

$$\begin{aligned} \text{Area of } efgh &= 200 \times 75 \text{ mm}^2 \\ &= 15000 \text{ mm}^2 \end{aligned}$$

$$\text{Total area} = (6000+15000) \text{ mm}^2$$

$$(abcd+efgh) = 21000 \text{ mm}^2$$

$$\begin{aligned} 2 \quad (6000 \text{ m}^2 \times 25) + (15000 \text{ mm}^2 \times 150 \text{ mm}) \\ &= (21000 \text{ mm}^2) \times (x \text{ mm}) \end{aligned}$$

$$150000 \text{ mm}^2 + 2250000 \text{ mm}^2 = (21000 \text{ mm}^2) \times (x \text{ mm})$$

$$2400000 \text{ mm}^2 = (21000 \text{ mm}^2) \times (x \text{ mm})$$

$$\text{Therefore } x = \frac{2400000 \text{ mm}^2}{21000 \text{ mm}^2}$$

$$= \frac{2400}{21} \text{ mm}$$

$$= \frac{800}{7} \text{ mm}$$

$$= 114.3 \text{ mm}$$

Hence c.g. point of composite figure is 114.3 mm from the line ab.

11 Centre of gravity point of a composite body can be found out by using a variation of principle of moments.

Example (Fig 11)

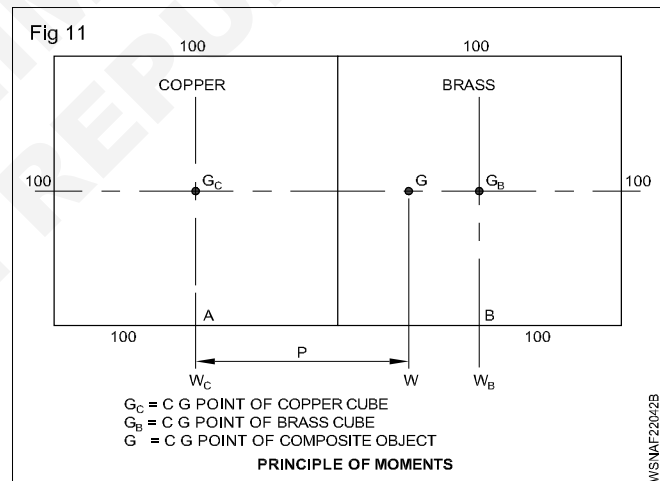

Moment of part "A" about O+ Moment of part "B" about O= Moment of (A+B) about O.

**The moment of the (A+B) acting through point G.**

A copper cube of 100mm side is attached to brass cube of 100 mm side as sketched in the figure (Fig 12) Calculate the position of c.g of composite object. Take densities of copper and brass as 8.9 gms/cm<sup>3</sup> and 8.5 gms/cm<sup>3</sup>

### Solution

$$\begin{aligned} \text{Volume of Copper/Brass cube} &= 100 \times 100 \times 100 \text{ mm}^3 \\ &= 10^6 \text{ mm}^3 \end{aligned}$$

$$= \frac{10^6 \text{ mm}^3}{10^3 \text{ mm}^3}$$

$$= 1000 \text{ cm}^3$$

Mass of copper cube = Volume x Density

$$= 1000 \times 8.9$$

$$= 8900 \text{ gms}$$

$$= \frac{8900}{1000} \text{ Kg}$$

$$= 8.9 \text{ Kg.}$$

(g=Acceleration due to gravity=10m/sec<sup>2</sup>)

Weight of copper cube = 8.9 kg x 10 m/sec<sup>2</sup>

Similarly = 89 N

Weight of brass cube =  $\frac{1000 \text{ cm}^3 \times 8.5 \times 10}{1000}$

(Take g = 10m/sec<sup>2</sup>) = 8.500 x 10 = 85N

**Let cg of separate cubes be G<sub>c</sub> and G<sub>B</sub> as shown in figure.**

**The distance between G<sub>c</sub> and G<sub>B</sub>=100mm or 0.1 m**

**Let c.g of the total object be at G which is 'P' metre to the right of G<sub>c</sub> or (0.1-P) metre to the left of G<sub>B</sub>.**

Take moments about G

Clock moments = W<sub>B</sub> x (0.1 - P)

$$= 85 \times (0.1 - P)$$

$$= 8.5 - 85P$$

Anti clock moments = W<sub>C</sub> x P

$$= 89 \times P \text{ [Nm]}$$

$$= 89P$$

By principle of moments

89P = 8.5 - 85P [Equating clock moments with anti-clock moments]

$$89P + 85P = 8.5$$

$$174P = 8.5$$

$$P = \frac{8.5}{174} \text{ metre or } 0.049 \text{ m or } 49 \text{ mm}$$

**Centre of gravity of the composite object lies 49 mm from point of G<sub>c</sub>. Hence it lies within copper cube.**

## Assignment A

- 1 Find the position of centre of gravity of the figure shown. (All dimensions in mm)

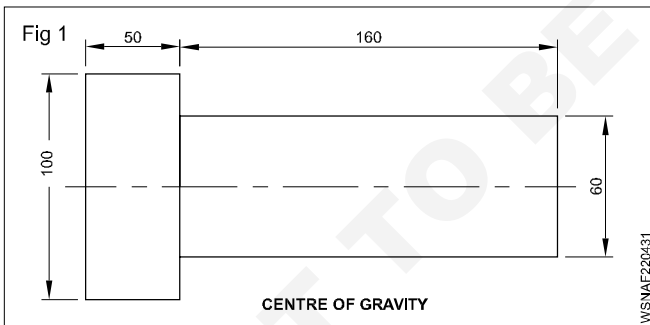

- 2 A lamina consists of a square of 60mm side, on one side of which an equilateral triangle is constructed. Find the position of centroid of the composite.

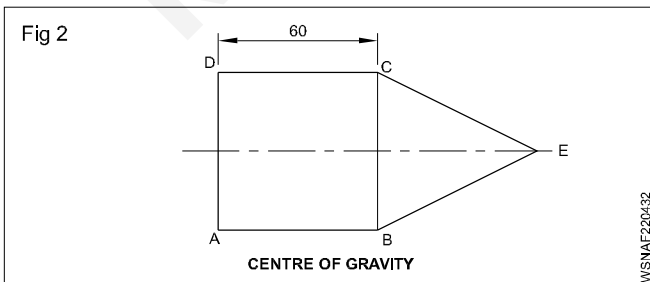

- 3 A steel strip 50x12x12cm has a hole of 8cm dia. drilled through it at a distance of 10cm from end. Find out the c.g of the strip.

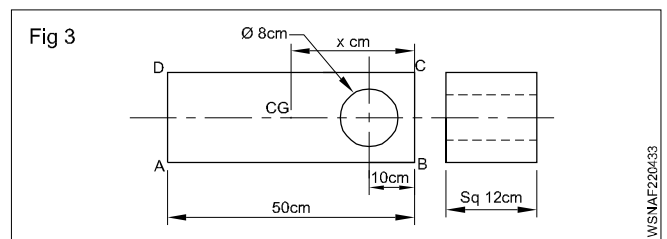

- 4 Find out the C.G. of the four sided figure ABCD when ∠A = ∠B=90° and the side AB=15cm, BC=12cm and AD=5cm.

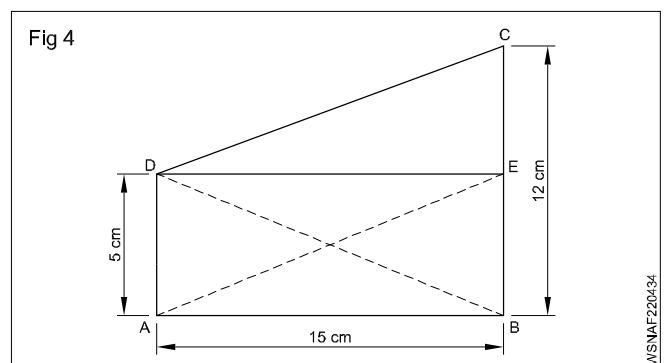

## Assignment B

---

- 1 What is the centre of gravity of a semi-circle is at a perpendicular distance from its centre?
- A  $\frac{3r}{4\pi}$                       B  $\frac{4r}{3\pi}$
- C  $\frac{8r}{3}$                          D  $\frac{3r}{8}$
- 2 What is the centre of gravity of a hemisphere is at a distance from its base.
- A  $\frac{2r}{8}$                          B  $\frac{3r}{8}$
- C  $\frac{4r}{8}$                          D  $\frac{5r}{8}$
- 3 What is the centre of gravity of a triangle is at the point where the medians of the triangle meet?
- A  $\frac{h}{2}$                          B  $\frac{h}{3}$
- C  $\frac{h}{4}$                          D  $\frac{h}{5}$
- 4 What is the centre of gravity of a right circular cone is at a distance from its base.
- A  $\frac{h}{2}$                          B  $\frac{h}{3}$
- C  $\frac{h}{4}$                          D  $\frac{h}{5}$
- 5 Centre of gravity is usually located where.
- A more weight is concentrated
- B less weight is concentrated
- C less mass is concentrated
- D more mass is concentrated
- 6 Centre of gravity of an object depends on it's.
- A weight                      B mass
- C density                      D shape
- 7 Point where whole weight of body acts vertically is called.
- A centre of mass              B mid point
- C centre of gravity            D none of above
- 8 A simple method to find centre of gravity of a body is usage of.
- A stop watch                  B plumbline
- C pendulum                    D screw gauge
- 9 If a material has no uniform density throughout the body, then the position of centroid and centre of mass are.
- A identical
- B not identical
- C independent upon the density
- D unpredictable
- 10 Which of the following laminas do not have centroid at its geometrical centre?
- A Circle                         B Equilateral triangle
- C Right angled triangle      D Isosceles triangle

Area of cut-out regular surfaces - Circle, segment and sector of circle

**Circle (Fig 1)**

It is the path of a point which is always equal from its centre is called a circle.

$r$  = radius of the circle

$d$  = diameter of the circle

Area of the circle =  $\pi r^2$

(or) =  $\frac{\pi}{4} d^2$  unit<sup>2</sup>

Circumference of the circle =  $2\pi r$  (or)  $\pi d$  unit

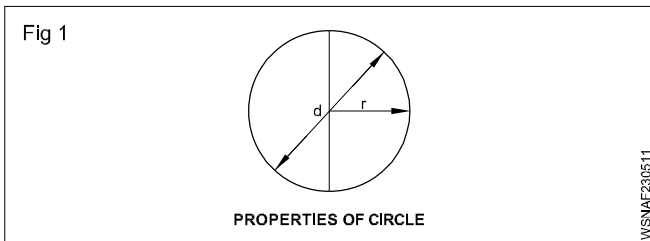

**Sector of a circle (Fig 2)**

The area bounded by an arc and two side radius is called the sector of a circle. In the figure given ABC is the sector of a circle.

$r$  = radius of the circle

$\theta$  = Angle of sector in degrees

Area of sector ABC

=  $\frac{\pi r^2 \times \theta}{360^\circ}$  unit<sup>2</sup>

Area of sector =  $\frac{\text{Length of arc of sector} \times \text{radius}}{2}$  unit<sup>2</sup>

Length of the arc  $l = 2\pi r \times \frac{\theta}{360^\circ}$  unit

Perimeter of the sector =  $l + 2r$  unit

$r$  = radius

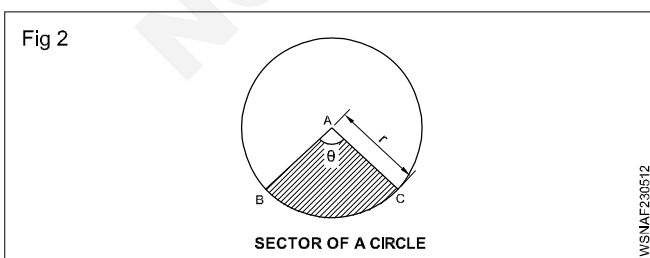

**Segment of a circle (Fig 3)**

When a circle is divided into two by drawing a line, the bigger part is called segment of the circle and the smaller part is also called segment of the circle.

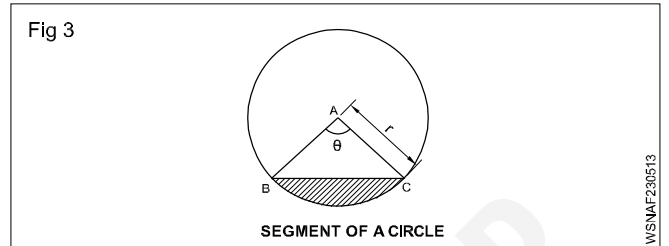

Area of the smaller segment

= Area of the sector - Area of  $\Delta ABC$

Area of the greater segment

= Area of the circle - Area of smaller segment

**Semi Circle (Fig 4)**

- A semi circle is a sector whose central angle is  $180^\circ$ .

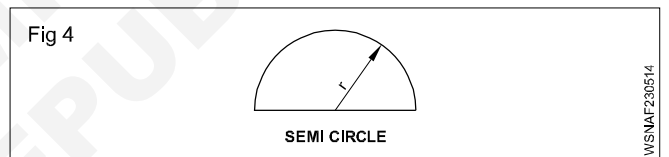

- Length of arc of semi circle

$l = 2\pi r \times \frac{180^\circ}{360^\circ} = 2\pi r \times \frac{1}{2}$  unit  
=  $\pi r$  unit

Area of semi circle =  $\frac{\pi r^2}{2}$  unit<sup>2</sup>

Perimeter of a semi circle =  $\frac{2\pi r}{2} + 2r$

=  $\pi r + 2r$

=  $r(\pi + 2)$  unit

**Quadrant of a circle (Fig 5)**

- A quadrant of a circle is a sector whose central angle is  $90^\circ$ .

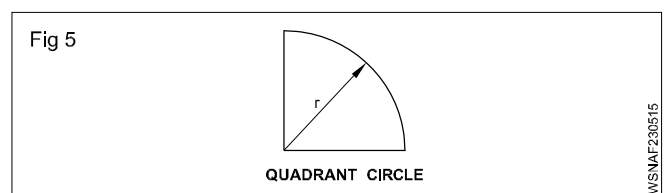

- Length of arc of quadrant of a circle

$$\begin{aligned} l &= 2\pi r \times \frac{90^\circ}{360^\circ} \\ &= 2\pi r \times \frac{1}{4} \\ &= \frac{\pi r}{2} \end{aligned}$$

$$\text{Area of quadrant of a circle} = \frac{\pi r^2}{4} \text{ unit}^2$$

$$\text{Perimeter of a quadrant} = \frac{2\pi r}{4} + 2r$$

$$\begin{aligned} &= \frac{\pi r}{2} + 2r \\ &= r \left( \frac{\pi}{2} + 2 \right) \text{ unit} \end{aligned}$$

#### Examples :

- 1 Find the area of a sector of a circle whose radius is 14 cm and the length of the arc of the sector is 28 cm.

Radius of sector  $r = 14$  cm

Length of arc of sector = 28 cm

$$\text{Length of arc of sector } (l) = \frac{\theta}{360^\circ} \times 2\pi r \text{ unit}$$

$$28 = \frac{\theta}{360^\circ} \times 2 \times \frac{22}{7} \times 14 \text{ unit}$$

$$\theta = \frac{28 \times 360^\circ \times 7}{2 \times 22 \times 14} = 114.55^\circ$$

$\therefore$  Angle of sector  $\theta = 114.55^\circ$

$$\begin{aligned} \therefore \text{Area of sector} &= \frac{\theta}{360^\circ} \times \pi r^2 \text{ unit}^2 \\ &= \frac{114.55}{360^\circ} \times \frac{22}{7} \times 14 \times 14 \text{ cm}^2 \\ &= 196 \text{ cm}^2 \end{aligned}$$

**Area of sector = 196 cm<sup>2</sup>**

- 2 If the circumference of a circle is 44 cm, find its area. (Take  $\pi = \frac{22}{7}$ )

#### Solution

$\therefore$  Let  $(d)$  = diameter of circle

$\therefore$  Circumference of circle =  $\pi d$

$$\therefore 44 = \pi \cdot d$$

$$d = \frac{44}{\pi} = 44 \div \pi$$

$$= 44 \div \frac{22}{7}$$

$$= 44 \times \frac{7}{22}$$

$$= 14 \text{ cm}$$

$\therefore$  Diameter of circle  $(d) = 14$  cm

$$\therefore \text{Area of circle} = \frac{\pi}{4} d^2 \text{ unit}^2$$

$$= \pi \times \frac{1}{4} d^2$$

$$= \frac{22}{7} \times \frac{1}{4} \times 14 \times 14$$

$$= 154 \text{ cm}^2$$

Area of circle = 154 cm<sup>2</sup>

- 3 Find the remaining area of circle of 10 cm dia after inscribing triangle of 5 cm base and 10 cm height.

#### Solution

$$\begin{aligned} \text{(i) Area of the circle} &= \frac{\pi}{4} d^2 \\ &= \frac{22 \times 10 \times 10}{7 \times 4} \text{ Unit}^2 \\ &= \frac{550}{7} = 78.57 \text{ cm}^2 \end{aligned}$$

(ii) Area of the triangle inscribed in this circle

$$= \frac{1}{2} \times \text{base} \times \text{height}$$

$$= \frac{10 \times 5}{2} = 25 \text{ sq.cm}$$

Remaining area = 78.57 - 25

Remaining area of circle = 53.57 cm<sup>2</sup>

- 4 A rectangular sheet of metal measures 8 cm and 6 cm. Four quadrants of circles each of radius 2 cm are cut away at corners. Find the area of the remaining portion.

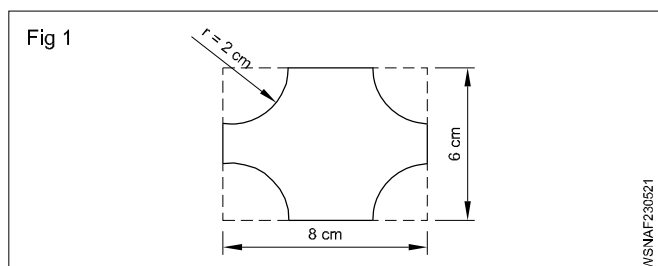



$$\begin{aligned} \text{Area of rectangular sheet} &= 8 \times 6 \\ &= 48 \text{ cm}^2 \end{aligned}$$

There are four quadrants of a circle, each of radius 2 cm cut away at the corners. Quadrant of circle means 1/4th of circle.

$$4 \text{ quadrant of circles} = 4 \times \frac{1}{4} \text{ of circle} = 1 \text{ circle}$$

$$\begin{aligned} \text{Area of 4 quadrant circles} &= \text{Area of one circle} \\ &= \pi r^2 \\ &= \frac{22}{7} \times 2 \times 2 \\ &= 12.57 \text{ cm}^2 \end{aligned}$$

$$\begin{aligned} \text{Area of remaining portion} &= \text{Area of rectangular sheet} - \\ &\quad \text{Area of four quadrant circles} \\ &\quad \text{cut at corners.} \\ &= 48 - 12.57 \\ &= 35.428 \text{ cm}^2 \\ &= \text{say } 35.43 \text{ cm}^2 \end{aligned}$$

$$\text{Area of remaining portion} = 35.43 \text{ cm}^2$$

## 5 Find the perimeter of the given circular disc.

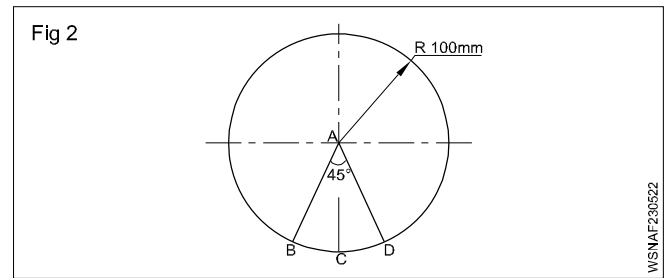

**Sector :**

$$\begin{aligned} r &= 100 \text{ mm} \\ \theta &= 360^\circ - 45^\circ = 315^\circ \end{aligned}$$

$$l = \frac{\theta}{360} \times 2\pi r \text{ unit}$$

$$= \frac{315}{360} \times 2 \times \pi \times 100 \text{ mm}$$

$$l = 550 \text{ mm}$$

$$\text{Perimeter of the given circular Disc} = l + 2r$$

$$= 550 + 200 = 750 \text{ mm}$$

**Perimeter of the given circular Disc = 750 mm**

## Elasticity - Elastic, plastic materials, stress, strain and their units and young's modulus

### Elastic material

The Elastic materials are those materials that have the ability to resist a distorting or deforming influence or force, and then return to their original shape and size when the same force is removed.

Linear elasticity is widely used in the design and analysis of structures such as beams, plates and sheets.

Elastic materials are of great importance to society since many of them are used to make clothes, tires, automotive spare parts, etc.

### Characteristics of elastic materials

When an elastic material is deformed with an external force, it experiences an internal resistance to the deformation and restores it to its original state if the external force is no longer applied.

To a certain extent, most solid materials exhibit elastic behavior, but there is a limit of the magnitude of the force and the accompanying deformation within this elastic recovery.

A material is considered as elastic if it can be stretched up to 3 times of its original length.

For this reason there is an elastic limit, which is the greatest force or tension per unit area of a solid material that can withstand permanent deformation.

For these materials, the elasticity limit marks the end of their elastic behavior and the beginning of their plastic behavior. For weaker materials, the stress or stress on its elasticity limit results in its fracture.

The elasticity limit depends on the type of solid considered. For example, a metal bar can be extended elastically up to 1% of its original length.

However, fragments of certain gummy materials may undergo extensions up to 10 times. The elastic properties of most solid intentions tend to fall between these two extremes.

Maybe you might be interested How to Synthesize an Elastolic Material?

### Examples of elastic materials

- 1 Natural gum
- 2 Spandex or lycra
- 3 Butyl Rubber (GDP)
- 4 Fluoroelastomer
- 5 Elastomers
- 6 Ethylene-propylene rubber (EPR)
- 7 Resilin
- 8 Styrene-butadiene rubber (SBR)
- 9 Chloroprene

- 10 Elastin
- 11 Rubber Epichlorohydrin
- 12 Nylon
- 13 Terpene
- 14 Isoprene Rubber
- 15 Poilbutadiene
- 16 Nitrile Rubber
- 17 Vinyl stretch
- 18 Thermoplastic elastomer
- 19 Silicone rubber
- 20 Ethylene-propylene-diene rubber (EPDM)
- 21 Ethylvinylacetate (EVA or foamy gum)
- 22 Halogenated butyl rubbers (CIIR, BIIR)
- 23 Neoprene

### Plastic Material

#### Plastic Material Classification

"Plastic material" is a term that refers to a large class of polymers, separated into various groups and sub-groups. Before starting the chapter on the uses and subsequent recycling of plastic, let us establish a general classification of these thermosetting resins or thermo-plastics (the two big groups into which we include elastomers) by detailing their properties, their make-up, their aspect, and their final uses, while explaining which ones are recyclable.

#### Thermoplastics

Remember that thermoplastic is a material whose structure and viscosity can be modified both ways through heating or cooling. This large family of materials is commonly used by many industries and is easily integrated into France's recycling cycles.

The following polymers are some examples of plastic material:

- 1 Polyolefins
- 2 Vinyl polymers
- 3 Polystyrenes
- 4 Acrylate and methacrymate polymers
- 5 Polyamide
- 6 Polycarbonates
- 7 Celluloid
- 8 Linear polyesters
- 9 Polyfluorethane
- 10 Polyacetal
- 11 Polysulfone

12 Polyphenylene sulfide

13 Modified polyphenylene oxide (PPO)

### Thermosetting plastic

Thermosetting plastic is a compound that, during condensation polymerisation and/or implementation, when submitted to a catalyst or a temperature increase, irreversibly cures. the structure, shape, or rigidity of the manufactured plastic object can not be modified again, and the material is rarely recycled.

This type of plastic includes the following types of compounds:

- 1 Unsaturated polyester
- 2 Phenol formaldehyde resins
- 3 Melamine resins
- 4 Polyepoxides
- 5 Polyimide
- 6 Polyurethane
- 7 Polyorganosiloxanes

Generally in any industry the material used are elastic in nature. Hence if a material is subjected to an external load, it undergoes deformation. During the deformation process the material will offer a resistance against the deformation. In case if the material fails to put up full resistance to the external load, the deformation continues until rupture takes place. Hence it is important to have a considerable knowledge about the materials and their properties for designing and fabricating.

### Force

Force is defined as an external source which changes or tends to change the state of rest or of uniform motion of an object. In other words everybody preserves in its state of rest or of uniform motion unless it is forced by an external source to change that state. That external source is called as Force. It has both magnitude and direction. So it is a vector quantity. In SI system, its unit is Newton.

Unit in MKS - kgf

1 kgf = 9.81 Newton

Force is defined as the product of mass of the object and the acceleration.

Force = mass x acceleration

$$\begin{aligned} F &= m \times a \\ &= \text{Kg} \times \text{m/sec}^2 \\ &= 1 \text{ Newton} \end{aligned}$$

### Causes of force

- Change in speed
- Change in direction
- Change in shape
- Change in dimension
- Change in condition (Rest to uniform motion and vice versa)

### Types of forces

- tensile force
- compressive force
- shear force.

**Tensile force:** When two equal and opposite forces act on a body and have the same line of action, and if they tend to increase the length of the body, the applied forces are called tensile forces. (Fig 1)

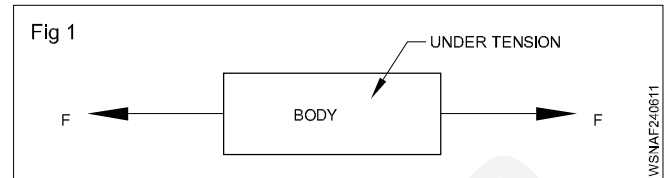

**Compressive force:** When two equal and opposite forces act on a body having the same line of action and if they tend to compress the body and try to reduce the length of the body, the forces applied are called compressive forces. (Fig 2)

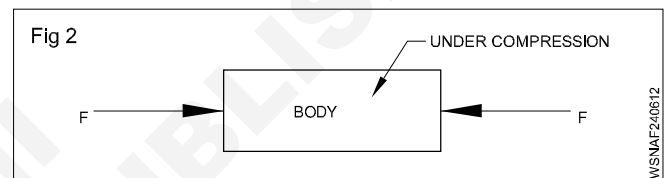

**Shear force:** When two equal and opposite forces having different lines of action act on a body such that one section of the body tends to slide over another section which results in a shearing action then the forces are referred to as shear forces. (Fig 3)

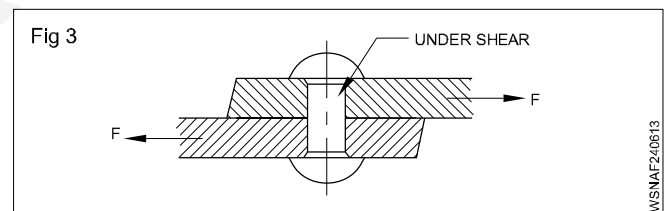

**Direct effect of forces:** Forces acting on a body can cause in the material. (Fig 4 & Fig 5)

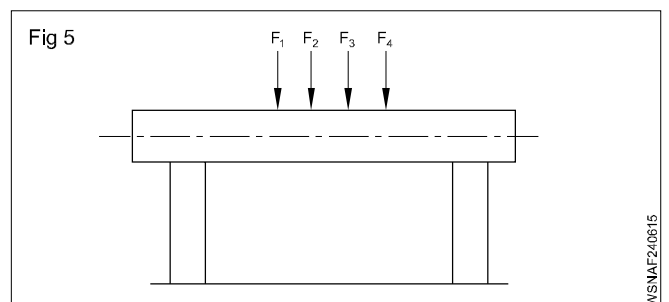
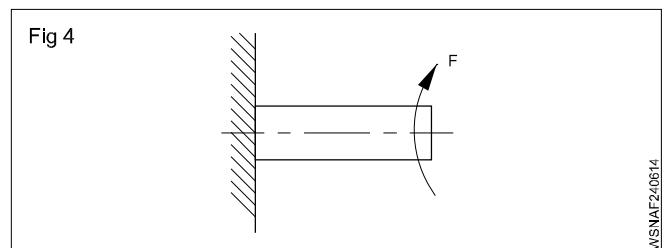

- Tension
- Compression
- Shearing effect
- Twisting effect
- Bending effect.

**Force is mainly classified as tensile force, compressive force and shear force.**

### Stress

The internal opposite force to the external load per unit area is known as stress. The unit of stress depends upon the force applied and area of original cross-section of material.

$$\therefore \text{Stress} = \frac{\text{Force applied}}{\text{Area of original cross section}}$$

$$= \frac{\text{Load(or)Force}}{\text{Area}} \left( \frac{\text{N}}{\text{mm}^2} \text{ or } \frac{\text{Kg}}{\text{cm}^2} \right)$$

$$\text{Shear stress} = \frac{F}{A} \left( \frac{\text{N}}{\text{cm}^2} \text{ or } \frac{\text{Kg}}{\text{cm}^2} \right)$$

### Types of Stress

- 1 Tensile stress
- 2 Compressive stress
- 3 Shear stress
- 4 Torsional Stress

- 1 **Tensile stress:** When a material is subjected to two equal and opposite axial pulls, the material tends to increase in length. The resistance offered against this increase in length is called tensile stress. The corresponding strain is called tensile strain. (Fig 6)

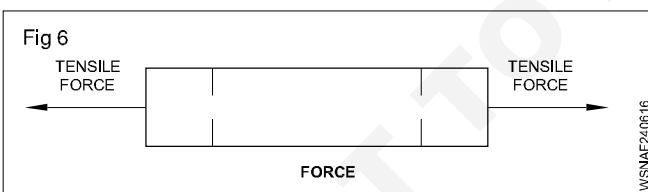

#### E.g.:

- 1 When brake is applied the brake rod is under tensile stress.
- 2 During tightening of bolt or nut.
- 3 Belt driving motor.
- 4 Crane rope (When rope is pulling)
- 2 **Compressive stress:** When a material is subjected to two equal and opposite axial pushes, the material tends to decrease in length. The resistance offered against

the decrease in length is called compressive stress. The corresponding strain is called compressive strain. (Fig 7)

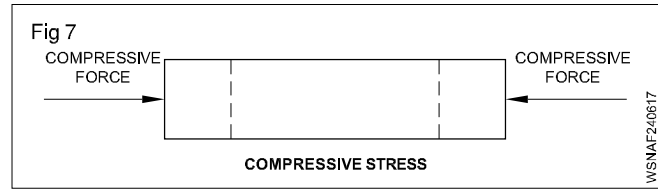

$$\text{Compressive stress} = \frac{\text{Axial push}}{\text{Area of cross section}}$$

$$\text{Compressive stress} = \frac{\text{Decrease in length}}{\text{Original length}}$$

#### Eg.

- 1 Compressive stress on connecting rod on the first part of power stroke
- 2 Compressive stress on push rod during valve opening
- 3 Clutch lining when the clutch is engaged
- 3 **Shear stress:** When a material is subjected to two equal and opposite forces acting tangentially across the resisting section, the body tends to be sheared off across the cross section. The stress included is called shear stress. It is represented by  $\tau$ . The corresponding strain is called shear strain. (Fig 8)

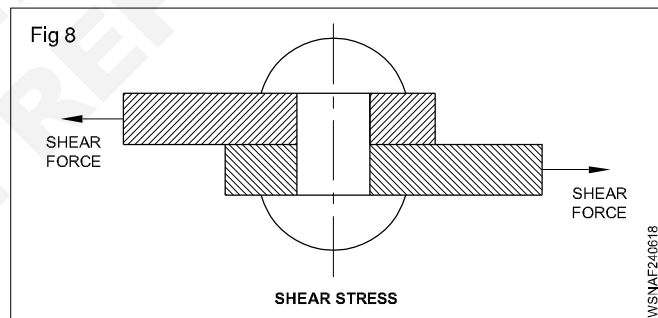

$$\text{Shear stress} = \frac{F}{A} \left( \frac{\text{N}}{\text{cm}^2} \text{ or } \frac{\text{Kg}}{\text{cm}^2} \right)$$

#### Eg.

- 1 Rivets
- 2 Gudgeon Pin
- 3 Spring shackle pin
- 4 Brake rod rivets
- 5 Chassis rivets
- 6 Fly wheel holding bolts
- 7 Swivel pins
- 8 Gear box shaft
- 9 Axle shaft

**4 Torsional stress:** When a shaft is subjected to the action of two equal and opposite couples acting in parallel planes, then the shaft is said to be in torsion. The stress set up by the torsion is known as torsional shear stress.

Eg.

- 1 Rear axle
- 2 Crank shaft
- 3 Coil springs
- 4 Propeller shaft
- 5 Starter motor armature shaft

**Examples**

**1 A steel wire 3 mm dia. is loaded in tension with a weight of 50 kg. Find out the stress developed.**

Diameter of the steel wire = 3 mm

Radius = 1.5 mm

Weight = 50 kg

$$\text{Stress} = \frac{\text{Force}(F)}{\text{Area}(A)}$$

Area of circular wire (A) =  $\pi r^2$  unit<sup>2</sup>

$$= \frac{22}{7} \times 1.5 \times 1.5$$

$$= \frac{49.5}{7} = 7.07 \text{ mm}^2$$

$$\text{Stress} = \frac{50}{7.07}$$

$$= 7.072 \text{ Kg/mm}^2$$

**2 A force of 500 N is applied on a metallic wire of 5mm diameter. Find the stress.**

Diameter of the wire = 5 mm

Radius = 2.5 mm

Force = 500 Newton

$$\text{Stress} = \frac{\text{Force}(F)}{\text{Area}(A)}$$

Area of circular wire (A) =  $\pi r^2$  unit<sup>2</sup>

$$= \frac{22}{7} \times 2.5 \times 2.5$$

$$= \frac{137.5}{7} = 19.64 \text{ mm}^2$$

$$\text{Stress} = \frac{500}{19.64}$$

$$= 25.46 \text{ N/mm}^2$$

**3 A load of 600 kg is placed on a hollow cast iron cylinder of 200 mm outer diameter and 100 mm internal diameter. Find the stress on the cylinder.**

**Hollow cylinder**

Outer diameter (D) = 200 mm = 20 cm

Outer radius (R) = 10 cm

Internal diameter (d) = 100 mm = 10 cm

Inner radius (r) = 5 cm

Weight = 600 kg

$$\text{Stress} = \frac{\text{Force}(F)}{\text{Area}(A)}$$

Area =  $\pi (R + r)(R - r)$

$$= \frac{22}{7} \times (10 + 5) \times (10 - 5)$$

$$= \frac{22}{7} \times 15 \times 5$$

$$= \frac{1650}{7} = 235.7 \text{ cm}^2$$

$$\text{Stress} = \frac{600}{235.7} \text{ kg/cm}^2$$

$$= 2.546 \text{ kg/cm}^2$$

**4 Calculate the minimum cross section area of a M.S. bar to withstand a load 6720 kg. Take the maximum stress of the material as 698.2 kg/cm<sup>2</sup>.**

Weight = 6720 kg

Maximum stress = 698.2 kg/cm<sup>2</sup>

$$\text{Stress} = \frac{\text{Force}(F)}{\text{Area}(A)}$$

$$\text{Area}(A) = \frac{6720}{698.2}$$

$$= 9.625 \text{ cm}^2$$

To calculate diameter

$$\text{Area} = \frac{\pi d^2}{4} \text{ unit}^2$$

$$d^2 = 4 \times 9.625 \times \frac{7}{22}$$

$$= \frac{134.75}{11}$$

$$d^2 = 12.25$$

$$d = 3.5 \text{ cm}$$

- 5 A load of 300 kg hanging from a rod of 3 metre length and 5 mm diameter extends it by 4 mm. Find the stress in the material and the strain it causes.**

Length of the rod = 3 m = 3000 mm

Increased length = 4 mm

Diameter = 5 mm;

Radius = 2.5 mm

Weight = 300 kg

$$\text{Strain} = \frac{\text{Change in length}}{\text{Original length}}$$

$$= \frac{4}{3000} = 0.00133$$

$$\text{Stress} = \frac{\text{Force}(F)}{\text{Area}(A)}$$

Area of circular rod (A) =  $\pi r^2$  unit<sup>2</sup>

$$= \frac{22}{7} \times 2.5 \times 2.5$$

$$= \frac{137.5}{7}$$

$$= 19.643 \text{ mm}^2$$

$$\text{Stress} = \frac{300}{19.643}$$

$$= 15.273 \text{ kg/mm}^2$$

- 6 Find the force required to punch a hole of 10 mm dia. in a 1 mm thick plate, if the allowable shear stress is 50 N/mm<sup>2</sup>.**

Thickness of the plate = 1 mm

Dia. of the punch = 10 mm

Shear stress = 50 Newton/mm<sup>2</sup>

Force = Shear stress x area

Shear area = Circumference x thickness

$$= \pi dt$$

$$= \frac{22}{7} \times 10 \times 1$$

$$= \frac{220}{7} = 31.43 \text{ mm}^2$$

Force = 50 x 31.43

$$= 1571.5 \text{ Newtons}$$

- 7 A hole of 30 mm diameter is punched in a plate of 5 mm thickness. If the shear stress is 400 kg/cm<sup>2</sup>. Find the force required to punch the hole.**

Thickness of the plate = 5 mm = 0.5 cm

Diameter of the punch = 30 mm = 3 cm

Shear stress = 400 kg/cm<sup>2</sup>

Force = Shear stress x area

Shear area = Circumference x thickness

$$= \pi dt$$

$$= \frac{22}{7} \times 3 \times 0.5$$

$$= \frac{33}{7} = 4.71 \text{ mm}^2$$

Required force = 400 x 4.71

$$= 1885.71 \text{ kg}$$

- 8 What force will be required to shear off a bar of 30 mm dia. if the ultimate shear stress of the material is 35 kg/mm<sup>2</sup>.**

Diameter of the bar = 30 mm

Shear stress = 35 kg/mm<sup>2</sup>

$$\text{Stress} = \frac{\text{Force}(F)}{\text{Area}(A)}$$

$$35 = \frac{F}{\pi \times 15 \times 15}$$

$$F = 35 \times \pi \times 15 \times 15 \text{ kg}$$

Required Force = 24750 kg

- 9 A Hole of 2 cm dia is to be punched out of a plate of 1.4 cm thick. If the force applied to the punching die is 12 KN. Calculate the shear stress.**

Dia. of the hole = 2cm

Thickness = 1.4 cm

Force = 12 KN

Shear stress = ?

Punched out area = Circumference of the hole x Thickness

$$= 2 \pi r \times t \text{ unit}^2$$

$$= 2 \times \pi \times 1 \times 1.4$$

$$= 2.8 \pi \text{ cm}^2$$

$$\text{Shear stress} = \frac{F}{A}$$

$$= \frac{12 \text{ KN}}{2.8 \pi \text{ cm}^2}$$

Shear stress = 1.364 KN/cm<sup>2</sup>

**10 A square rod of 10 mm side is tested for a tensile load of 1016 kg. Calculate the tensile stress?**

Side of square rod (a) = 10 mm  
 Tensile force (F) = 1016 kg  
 Tensile stress ( $\sigma$ ) = ?

$$\begin{aligned} \text{Stress} &= \frac{\text{Force}(F)}{\text{Area}(A)} \\ &= \frac{\text{Force}}{a^2} \\ &= \frac{1016}{10 \times 10} \\ \text{Tensile stress} &= 10.16 \text{ Kg/mm}^2 \end{aligned}$$

**11 A M.S. tie bar 3.5 cm dia. is under a state of stress which carries a load of 6720 kg. Find the intensity of stress in the material.**

d = 3.5 cm  
 r = 1.75 cm  
 F = 6720 kg

$$\begin{aligned} \text{Stress} &= \frac{\text{Force}(F)}{\text{Area}(A)} \\ &= \frac{\text{Force}}{\pi r^2} \\ &= \frac{6720}{3.14 \times 1.75 \times 1.75} \\ &= \frac{6720}{9.616} \end{aligned}$$

**Intensity of stress = 698.8 Kg/cm<sup>2</sup>**

**12 A rivet of 10 mm dia. is subjected to a double shear force of 1.5 KN. Find the shear stress in the rivet.**

dia. of the rivet = 10 mm  
 r = 5 mm  
 Shear stress = ?

Double shear force is acting on the rivet, consider the area as double.

$$\begin{aligned} \text{Stress} &= \frac{F}{2\text{Area}} \\ &= \frac{1.5}{2 \times 3.14 \times 5 \times 5} \end{aligned}$$

**Shear stress = 0.00955 KN/mm<sup>2</sup>**

## Strain

When an external forces acting on a material, there is a change in its dimension and shape. The deformation is called strain. Thus, strain is the ratio between the change in dimension of a material to its original dimension. It has no unit. It is represented by E (Epsilon)

$$\text{Strain} = \frac{\text{Change in dimension } (\delta \ell)}{\text{Original dimension } (\ell)}$$

## Linear or Longitudinal strain

It is the ratio between the change in length of the material to its original length.

$$\text{Linear Strain} = \frac{\text{Change in length } (\delta \ell)}{\text{Original length } (\ell)}$$

## Lateral Strain

It is the ratio between change in cross sectional area of material to its original area.

$$\text{Lateral Strain} = \frac{\text{Change in area}}{\text{Original Area}}$$

## Volumetric Strain

It is the ratio between change in volume of material to its original volume.

$$\text{Volumetric Strain} = \frac{\text{Change in volume}}{\text{Original Volume}}$$

## Poisson's ratio

It is a ratio between lateral strain and linear strain.

$$\text{Poisson's ratio} = \frac{\text{Lateral strain}}{\text{Linear strain}} = \frac{1}{m}$$

## Examples

**1 Calculate the tensile strain when a force of 3.2 kN is applied to a bar of original length 280 cm extends the bar by 0.5 mm (Fig 1 & Fig 2)**

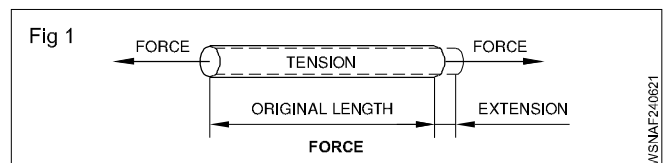

$$\begin{aligned} \text{Force} &= 3.2 \text{ kN} \\ \text{Original length (L)} &= 280 \text{ cm} \\ \text{Increased length } (\Delta \ell) &= 0.5 \text{ mm} = 0.05 \text{ cm} \\ \text{Tensile Strain} &= \frac{\text{Increased length}}{\text{Original Length}} \\ &= \frac{0.05}{280} \end{aligned}$$

**Tensile strain = 0.0001786**

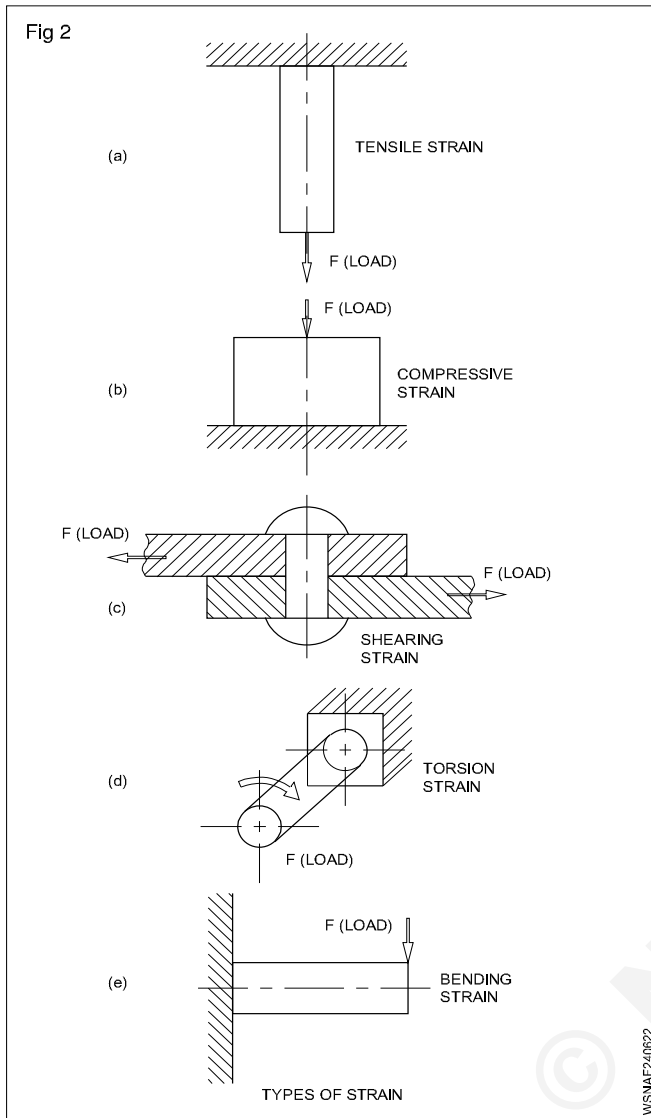

- 2 A steel rod used for brake operation is 1.50 m long. When it is subjected to a tensile force the extension produced is 0.5 mm. Find the strain in the rod.

$$\begin{aligned} \text{Tensile strain} &= \frac{\text{Extension}}{\text{Original length}} \\ &= \frac{0.5}{1.5 \times 1000} \left( \frac{\text{mm}}{\text{mm}} \right) \end{aligned}$$

Strain in the brake rod = 0.0003

- 3 A helical spring is loaded with a force of 600 Newton and is compressed by 30mm. What would be the load required to compress it to 10 mm. (Fig 3)

Solution

$$\text{Spring stiffness} = \frac{\text{Applied load}}{\text{Compression}}$$

$$= \frac{600 \left( \frac{\text{N}}{\text{mm}} \right)}{30} = 20 \left( \frac{\text{N}}{\text{mm}} \right)$$

Load required to compress the spring by 10 mm

$$= \text{spring stiffness} \times \text{compression}$$

$$= 20 \text{ (N/mm)} \times 10 \text{ (mm)}$$

$$\text{Load required} = 200 \text{ N}$$

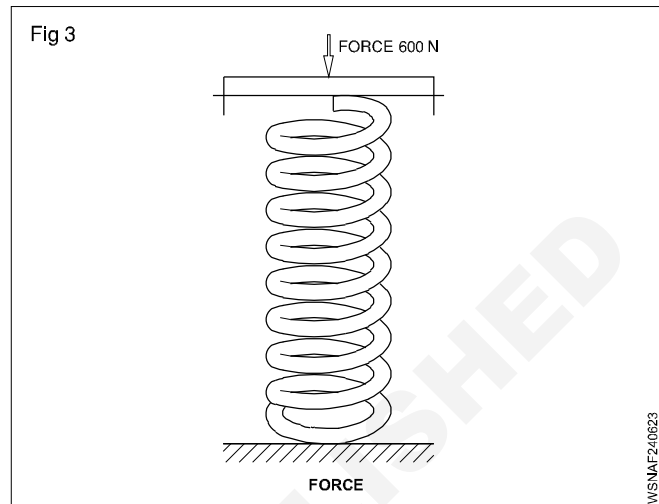

- 4 Helical spring is loaded with a force of 400 Newton and it is compressed by 18 mm. What would be the load required to compress it to 6 mm?

Given force = 400 Newton

Deflection = 18 mm

Spring Stiffness = Force / Compressed length

$$= 400 / 18$$

$$= 22.22 \text{ Newton / mm}$$

Force required to

compress the

spring into 6 mm

$$= \text{Spring stiffness} \times \text{Compression}$$

$$\text{Load required} = 22.22 \times 6$$

$$= 133.32 \text{ N}$$

- 5 Calculate the tensile strain when a force of 3.2 KN is applied to a bar of original length 2.8 m extends the bar by 0.5 mm.

Force F = 3.2 KN

Original length L = 280 cm

Increased length ( $\Delta \ell$ ) = 0.5 mm = 0.05 cm

Tensile strain = ?

$$\text{Strain} = \frac{\Delta \ell}{L}$$

$$= \frac{0.05}{280}$$

$$\text{Tensile strain} = 0.0001786$$



- 6 A metal bar is 2m long. When 5.5 tonne is applied its length becomes 1.995 m. Find the compressive strain?

$$\begin{aligned} \text{Force } F &= 5.5 \text{ KN} \\ \text{Original length } L_1 &= 2 \text{ m} \\ \text{Final length } L_2 &= 1.995 \text{ m} \\ \text{Increased length } (\Delta l) &= 2 - 1.995 = 0.005 \text{ m} \end{aligned}$$

$$\begin{aligned} \text{Compressive strain} &= \frac{\Delta l}{L} \\ &= \frac{0.005}{2} \end{aligned}$$

$$\text{Compressive strain} = 0.0025$$

- 7 When a steel rod of 4mm diameter experienced the load of 200 Kg. It is found to be elongated by 1.5 mm from the original length of 1500 mm. Calculate the strain.

$$\begin{aligned} \text{Force } F &= 200 \text{ Kg.} \\ \text{Original length } L_1 &= 1500 \text{ mm} \\ \Delta l &= 1.5 \text{ mm} \end{aligned}$$

$$\text{Strain} = ?$$

$$\begin{aligned} \text{strain} &= \frac{\Delta l}{L} \\ &= \frac{1.5}{1500} \end{aligned}$$

$$\text{strain} = 0.001$$

- 8 An iron rod of length 1 metre and 1 cm diameter gets elongated by 1 cm. When a force of 100 Kg is applied at one end. Calculate the strain developed in the rod.

$$\begin{aligned} \text{Force } F &= 100 \text{ Kg.} \\ \text{Original length } L_1 &= 1 \text{ m} = 100 \text{ cm} \\ \Delta l &= 1 \text{ cm} \end{aligned}$$

$$\text{Strain} = ?$$

$$\begin{aligned} \text{strain} &= \frac{\Delta l}{L} \\ &= \frac{1}{100} \end{aligned}$$

$$\text{Compressive strain} = 0.01$$

### Elasticity and Elastic limit

When an external force acts on a body, the body tends to undergo some deformation. If the external force is removed and the body comes back to its original shape and size (Which means the deformation disappears completely). The body is known as elastic body. This property by virtue

of which certain materials return back to their original position after the removal of the external force is called elasticity.

The body will regain its previous shape and size only when the deformation caused by the external force is within a certain limit. Thus there is a limiting value of force up to and within which the deformation completely disappears on the removal of the force. The value of stress corresponding to this limiting force is known as elastic limit of the material.

If the external force is so large that the stress exceeds the limit, the material loses to some extent its property of elasticity. If now the force is removed, the material will not return to its original shape and size and there will be a residual deformation in material.

### Yield point

The yield point of a material is the point at which there is a marked increase in elongation without increase in load.

### Hooke's law

Robert Hooke discovered a relationship between stress and strain. According to Hooke's law stress is proportional to strain within elastic limit.

### Young's Modulus or Modulus of Elasticity

The ratio of stress to strain within elastic limit is known as young's modulus or modulus of elasticity. This is expressed by a symbol "E". The unit of Young's modulus is same that of stress.

$$\therefore \text{Young's modulus (E)} = \frac{\text{Stress}}{\text{Strain}}$$

### Modulus of Rigidity

The ratio of shear stress to shear strain is known as "modulus of rigidity" represented by symbol "N".

$$\therefore \text{Modulus of Rigidity (N)} = \frac{\text{Shear stress}}{\text{Shear strain}}$$

### Bulk Modulus

When a body is subjected to three mutually perpendicular forces of the same intensity, the ratio of volumetric stress to the volumetric strain is known as Bulk Modulus. It is usually represented by the letter K.

$$\therefore \text{Bulk Modulus (K)} = \frac{\text{Volumetric stress}}{\text{Volumetric strain}}$$

### Relationship between three moduli for a given material

The relationship between three moduli for a given material is as follows :

$$E = 2N \left( 1 + \frac{1}{m} \right) = 3K \left( 1 - \frac{2}{m} \right)$$

Where

E = Young's modulus of elasticity

N = Modulus of rigidity

K = Bulk modulus

$\frac{1}{m}$  = Poisson's ratio

$$= \frac{4500}{\pi \times 6.25}$$

$$= \frac{4500 \times 4}{\pi \times 6.25}$$

$$= \frac{2880}{\pi}$$

### Example

1 A steel rod of 10 mm diameter and 175 mm long is subjected to a tensile load of 15 kN. If E = 2 x 10<sup>5</sup> N/mm<sup>2</sup>, calculate the change in length.

Tensile load = 15 kN = 15000 N

Area of cross section =  $(\pi r^2) = \frac{22}{7} \times 5 \times 5 \text{ mm}^2 = 78.57$

$$\therefore \text{Stress} = \frac{15000 \text{ N}}{0.785 \times 100 \text{ mm}^2} = 191 \text{ N/mm}^2$$

Young's modulus E =  $\frac{\text{Stress}}{\text{Strain}}$

$$E = 2 \times 10^5 \text{ N/mm}^2 = \frac{191 \text{ N/mm}^2}{\text{Strain}}$$

$$\therefore \text{Strain} = \frac{191}{2 \times 10^5}$$

$$\text{Change in length} = \frac{175 \times 191}{2 \times 10^5} \text{ mm}$$

$$= 0.167 \text{ mm.}$$

2 A bar of steel 2.5 cm diameter was subjected to compressive load of 4500 kg. The compression in a length of 20 cm was found to be 0.008 cm. Find the Young's modulus of elasticity of bar.

### Solution

Diameter of bar (d) = 2.5 cm

Force applied i.e. compressive load = 4500 kg

Original length of bar = 20 cm

Change in length = 0.008 cm

$$\therefore \text{Area of original cross-section} = \frac{\pi}{4} d^2$$

$$= \frac{\pi}{4} \times 2.5^2$$

$$= \frac{\pi \times 6.25}{4} \text{ cm}^2$$

$$\therefore \text{Stress} = \frac{\text{Force applied}}{\text{Area of original cross section}}$$

$$\therefore \text{Stress} = \frac{2880}{\pi} \text{ Kg/cm}^2$$

$$\therefore \text{Strain} = \frac{\text{Change in length}}{\text{Original length}}$$

$$= \frac{0.008}{20} = \frac{8/1000}{20}$$

$$= \frac{8}{20 \times 1000} = \frac{4}{10000}$$

$$\therefore \text{Strain} = \frac{4}{10000}$$

$$\therefore \text{Young's modulus} = \frac{\text{Stress}}{\text{Strain}}$$

$$= \frac{2880}{\pi} \div \frac{4}{10000}$$

$$= \frac{2880}{\pi} \times \frac{10000}{4}$$

$$= \frac{7200000}{\pi}$$

$$= 2292000 \text{ Kg/cm}^2$$

$$= 2.292 \times 10^6 \text{ Kg/cm}^2$$

3 A force of 10 tonnes is applied axially on a rod of 1.2 cm dia. the original length is 100 mm. If modulus of elasticity is 2 x 10<sup>12</sup> kg/cm<sup>2</sup>. Calculate stress and strain developed in the rod.

### Solution

Force applied = 10 tonnes = 10 x 1000 kg

$$= 10^4 \text{ kg}$$

Diameter (d) = 1.2 cm

Young's modulus (E) = 2 x 10<sup>12</sup> kg/cm<sup>2</sup>

$$\text{Stress} = \frac{\text{Force applied}}{\text{Area of original cross section}}$$

$$= \frac{4 \times 10^4}{\pi \times 1.2 \times 1.2}$$

$$= \frac{10^4 \times 4}{1.2 \times 1.2 \times 3.142}$$

$$= \frac{40000}{4.52448}$$

$$= 8841 \text{ kg/cm}^2$$

$$\therefore \text{Stress} = 8841 \text{ kg/cm}^2$$

We know

$$\frac{\text{Stress}}{\text{Strain}} = \text{Young's modulus}$$

$$\text{Strain} \times \text{Young's modulus} = \text{Stress}$$

$$\text{Strain} = \frac{\text{Stress}}{\text{Young's Modulus}}$$

$$= \frac{8841}{2 \times 10^{12}}$$

$$= \frac{4420.5}{10^{12}}$$

$$= 4420.5 \times 10^{-12}$$

$$\text{Stress} = 8841 \text{ kg/cm}^2$$

$$\text{Strain} = 4420.5 \times 10^{-12}$$

- 4 A bar of 100 cm elongates to 101.36 cm when a load of 15000 kg is applied to it. Take the area of cross section of bar as 10 cm<sup>2</sup>. Find the stress, strain and young's modulus.

$$L_1 = 100 \text{ cm}$$

$$L_2 = 101.36 \text{ cm}$$

$$\begin{aligned} \Delta l &= L_2 - L_1 \\ &= 101.36 - 100 = 1.36 \text{ cm} \end{aligned}$$

$$F = 15000 \text{ kg}$$

$$A = 10 \text{ cm}^2$$

$$\text{Stress} = \frac{\text{Force}(F)}{\text{Area}(A)}$$

$$= \frac{15000}{10}$$

$$= 1500 \text{ kg/cm}^2$$

$$\text{Strain} = \frac{\Delta l}{L}$$

$$= \frac{1.36}{100}$$

$$= 0.0136$$

$$\text{Young's modulus} = \frac{\text{Stress}}{\text{Strain}}$$

$$E = \frac{1500}{0.0136}$$

$$= 110300 \text{ kg/cm}^2$$

- 5 What force is required to stretch a steel wire of 10 mm long and 10 mm dia. to double its length. E of steel is 205 KN/cm<sup>2</sup>.

$$d = 10 \text{ mm} = 1 \text{ cm}$$

$$r = 0.5 \text{ cm}$$

$$L_1 = 1 \text{ cm}$$

$$L_2 = 2 \text{ cm}$$

$$\Delta l = L_2 - L_1 = 2 - 1 = 1 \text{ cm}$$

$$E = 205 \text{ KN/cm}^2$$

$$\text{Strain} = \frac{\Delta l}{L} = \frac{1}{1} = 1$$

$$E = \frac{\text{Stress}}{\text{Strain}}$$

$$205 = \frac{\text{Stress}}{1}$$

$$\text{Stress} = 1 \times 205 = 205 \text{ KN/cm}^2$$

$$\text{Stress} = \frac{\text{Force}(F)}{\text{Area}(A)}$$

$$205 = \frac{\text{Force}}{3.14 \times 0.5 \times 0.5}$$

$$\begin{aligned} \text{Force} &= 205 \times 3.14 \times 0.5 \times 0.5 \\ &= 161 \text{ KN} \end{aligned}$$

- 6 A wire of 1.6 cm diameter is subjected to a tensile load of 2000 Kg. Find the stress and strain if young's modulus = 2 x 10<sup>6</sup> kg/cm<sup>2</sup>.

$$F = 2000 \text{ kg}$$

$$d = 1.6 \text{ cm}$$

$$r = 0.8 \text{ cm}$$

$$E = 2 \times 10^6 \text{ Kg/cm}^2$$

$$\text{Stress} = \frac{F}{A}$$

$$= \frac{2000}{\pi r^2}$$

$$= \frac{2000}{3.14 \times 0.8 \times 0.8}$$

$$= \frac{2000}{2.0096}$$

$$= 995.2 \text{ kg/cm}^2$$

$$\text{Young's modulus} = \frac{\text{Stress}}{\text{Strain}}$$

$$2 \times 10^6 = \frac{995.2}{\text{Strain}}$$

$$\text{Strain} = \frac{995.2}{2 \times 10^6}$$

$$= 0.0005$$

$$\text{Stress}(\sigma) = \frac{\text{Force}(F)}{\text{Area}(A)} = \frac{\text{Force}}{l \times b}$$

$$= \frac{2000}{2 \times 1}$$

$$= 1000 \text{ kg/cm}^2$$

$$E = \frac{\text{Stress}}{\text{Strain}}$$

$$2 \times 10^6 = \frac{1000}{\text{Strain}}$$

$$\text{Strain} = \frac{1000}{2 \times 10^6}$$

$$= 0.0005$$

7 A tensile load of 2000 kg is applied on a rectangular rod of 2 cm x 1 cm whose length is 2 metres. Calculate the elongation in length as  $E = 2 \times 10^6 \text{ Kg/cm}^2$ .

$$F = 2000 \text{ Kg.}$$

$$L_1 = 2 \text{ m} = 200 \text{ cm}$$

$$E = 2 \times 10^6 \text{ kg/cm}^2$$

Rectangular rod length = 2 cm

Breadth = 1 cm

$$\frac{\Delta l}{L_1} = \text{Strain}$$

$$\frac{\Delta l}{200} = 0.0005$$

$$\Delta l = 200 \times 0.0005$$

$$= 0.1 \text{ cm}$$

$\therefore$  Elongated length = 0.1 cm

## Assignment

### Stress

- 1 Calculate the intensity of stress in the material if a copper rod of 40 mm diameter is subjected by tensile load of 4000 Newton's.
- 2 Calculate the intensity of stress if a mild steel rod having a cross sectional area of 40 mm<sup>2</sup> is subjected to the load of 1000 kg.
- 3 Calculate the tensile stress if a square rod of 10 mm side is tested for a tensile load of 1000 kg.
- 4 Calculate the maximum stress if a bar of 9 cm<sup>2</sup> cross sectional area and 300 cm long carries a tensile load of 3500 kg.
- 5 Find out the stress on the rod. if a load of 500 kg is placed on a M.S.rod of dia. 35 mm.
- 6 A metallic bar of 8 cm diameter is under stress carrying a load of 8620 N. Calculate the intensity of stress.
- 7 A steel wire 2 mm diameter is loaded in tension with a weight of 20 kg. Find out the stress developed.

- 8 A rod having a cross sectional area of 25 mm<sup>2</sup> is subjected to a load of 1500 kg. Find out stress on the rod.
- 9 A square rod of 10 mm side is tested for a tensile load of 2500 kg. Calculate the tensile stress of the rod.

### Strain

- 1 Find the compressive strain if a metal bar is 150 cm long. When 2.5 KN is applied, its length becomes 148.6 cm.
- 2 Calculate the strain if a metallic bar is 150 cm long. When 2500 kg is applied its length becomes 150.5 cm.
- 3 Find the strain it causes if a load of 300 kg hanging from a rod of 3 metres length and 5 mm diameter extends it by 4 mm.
- 4 A tensile force of 10 kg is applied on a copper wire of diameter 1 cm. So that the length of wire increases by 5 mm. If the original length of wire was 2 metres, find out the strain.

- 5 A steel rod whose diameter is 1 cm and 60 cm in length. This rod is pulled at both ends by a force of 700 kg. If modulus of elasticity of steel is  $2.1 \times 10^6 \text{ kg/cm}^2$ , find out increase in length of rod and strain produced in it.
- 6 A steel rod 1.5 metres long and of 30 mm diameter is pulled at both ends by a force of 1500 kg. If modulus of elasticity of steel is  $2.4 \times 10^6 \text{ kg/cm}^2$ , determine increase in length of rod and strain produced in it.
- 7 Calculate the change in length of a rod of dia 16 mm and 160 mm long when it carries a load of 40KN. Take  $E = 200000 \text{ N/mm}^2$ .
- 8 A hollow C.I. column with a wall thickness of 2 cm is subjected to an axial compressive load of 80 tonnes. If the maximum stress is not to be exceeded 1 tonne per  $\text{cm}^2$ , determine the internal diameter of column. Calculate compressive strain, if  $E = 950 \text{ tonnes per cm}^2$ .
- 4 A wire 2800 mm long is stretched by 0.5 mm, when a weight of 9 kg is hung on it, its diameter is 2 mm. Calculate stress and young's modulus for the substance of the wire.
- 5 A force of 1000 kg is applied axially on rod of 12 mm diameter the original length is 100 mm. If modulus of elasticity is  $2 \times 10^{12} \text{ kg/cm}^2$ . Calculate the stress and strain developed in the rod.
- 6 A steel wire 3.2 mm diameter and 3.65 metre long stretches by 2.03 mm under the load of 115 kg. Calculate the stress and young's modulus of elasticity.
- 7 A mass of 10 kg is hung from a vertical wire 300.25 cm long and 0.0005 sq. cm cross section. When the load is removed the wire is found to be 300 cm long. Find the modulus of elasticity for the wire material.

### Young's modulus

- 1 A piece of wire 2 m long,  $0.8 \text{ mm}^2$  in cross section increases its length by 1.6 mm on suspension of 8 kg weight from it. Calculate the stress, strain and young's modulus.
- 2 A wire of 16 mm dia. is subjected to a tensile load of 2000 kg. Find the stress and strain if young's modulus  $E = 2 \times 10^{16} \text{ kg/cm}^2$ .
- 3 A wire of 2 metres long and its area of cross section is  $0.78 \text{ mm}^2$ . If 78 kg weight is suspended on this wire, then the length of the wire is increased by 1.4 mm. Find out stress, strain and young's modulus of elasticity.
- 8 A steel rod of 1.5 cm diameter and 8 metres long pulled by a force of 80 kg at both ends. Find out the expansion and strain on the rod. The coefficient of elasticity  $E = 2.10 \times 10^6 \text{ kg/cm}^2$ .
- 9 A wire of length 3.5 m and diameter 0.35 mm is stretched by a force of 2kg weight. If the elongation is 4 mm. Calculate the young's modulus of the material of wire.
- 10 A mass of 1kg is suspended from a metal wire 100 cm long and 0.5 mm diameter. An increase in length of wire equal to 2 mm is observed. Calculate the young's modulus of wire.
- 11 A 4 metre long copper wire of diameter 3 mm is used to support a mass of 50kg. What will be the elongation of the wire. Young's modulus of elasticity for copper is  $7 \times 10^{10} \text{ N/mm}^2$ .

Elasticity - Ultimate stress and working stress

Ultimate stress and Working stress

The minimum load at which a material develops failure is called as ultimate load or breaking load. The stress produced in a material at ultimate load is called as ultimate stress or breaking stress.

$$\therefore \text{Ultimate stress} = \frac{\text{Ultimate load}}{\text{Area of original cross section}}$$

The load which is considered safe for the machine element is known as safe load or working load and the corresponding stress at this load is called as safe stress or working stress.

$$\therefore \text{Safe stress} = \frac{\text{Safe load}}{\text{Area of original cross section}}$$

Factor of safety (Fig 1)

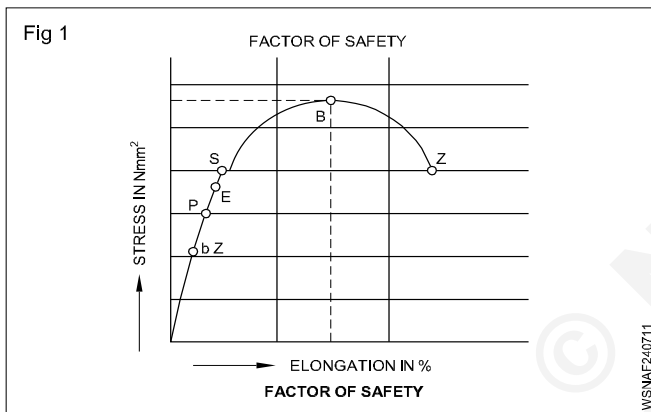

The ratio of ultimate stress to working stress (i.e. safe stress) is known as factor of safety. The ratio of ultimate load to the safe load may also be termed as factor of safety. It has no unit. Hence it is expressed in a number.

$$\text{Factory of safety} = \frac{\text{Ultimate stress}}{\text{Working stress}}$$

or

$$\text{Factor of safety} = \frac{\text{Ultimate load}}{\text{Safeload}}$$

Stress-Strain graph

Load-extension graph (Fig 2)

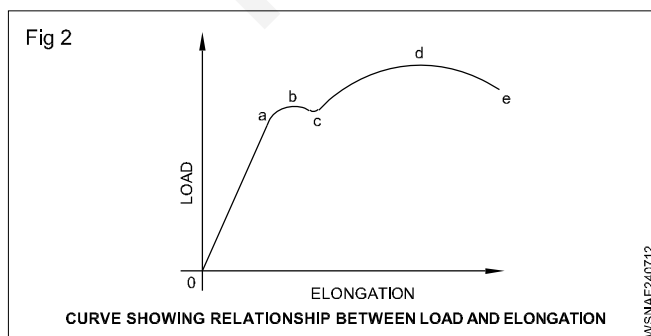

A metal (say mild steel) is subjected to increasing load and the extensions are measured with an extensometer. On plotting a graph between the loads and elongations produced, in the beginning, there is a straight-line relationship. It continues up to 'a' which is called the limit of proportionality, i.e. up to 'a' in Fig 2 'Stress is proportional to strain'.

Point b denotes the elastic limit. Below this point, the body regains its original shape, if the load is removed. Beyond this point the body does not recover its original shape completely, even if the load is removed.

Upto a point beyond the elastic limit, a considerable amount of elongation takes place even with a slight increase in load. The point C where it occurs, is called the yield point.

At 'd' the maximum or the ultimate load is reached. After this, a waist or local contraction is formed in the specimen, and fracture occurs as illustrated in Figure.

Example

A standard steel bar of 30 mm square cross section is subjected to tensile stress. If the factor of safety is 4 and ultimate stress is 370 N/mm<sup>2</sup> determine the load to which the bar is subjected. (Fig 3)

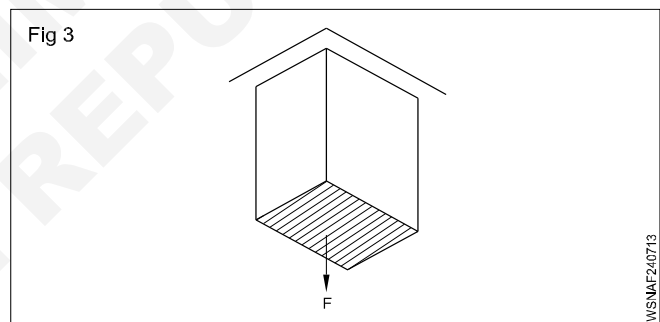

$$\frac{\text{Ultimate stress}}{\text{Working stress}} = \text{Factor of safety} = 4$$

$$\text{Working stress} = \frac{370}{4} \text{ N/mm}^2 = 92.5 \text{ N/mm}^2$$

$$\text{Area of cross section} = 900 \text{ mm}^2$$

$$(a^2 = 30^2 = 900, a = \sqrt{900} = 30)$$

$$\text{Load} = \text{Working tensile stress} \times \text{area}$$

$$= 900 \text{ mm}^2 \times \frac{370}{4} \text{ N/mm}^2$$

$$= 83250 \text{ N}$$

Example

1 A rod of Ø60 mm is subjected to a maximum tensile load of 1600 kg. Calculate the stress and strength of the material. If the factory of safety is 5.

$$\text{Dia. of rod (d)} = 60 \text{ mm}$$

$$\text{Tensile load (F)} = 1600 \text{ kg}$$

i Stress =  $\frac{F}{A} = \frac{1600}{\pi \times 30 \times 30}$   
 = 0.5658 kg/mm<sup>2</sup> Ans.

ii Factor of safety = 5

Factor of safety =  $\frac{\text{Ultimate stress}}{\text{Working stress}}$

5 =  $\frac{\text{Ultimate stress}}{0.5685 \text{ kg/mm}^2}$

Ultimate stress = 5 × 0.5658 kg/mm<sup>2</sup>

Strength of the material = 2.829 kg/mm<sup>2</sup>

2 Find the safe load which can be suspended from a 4.2 mm dia. wire. If the ultimate stress is 25 kg/mm<sup>2</sup> and the factor of safety is 4.

Dia. of wire d = 4.2 mm

Ultimate stress U.S = 25 kg/mm<sup>2</sup>

Factor of safety (FS) = 4

FS. =  $\frac{\text{Ultimate stress}}{\text{Working stress}}$

4 =  $\frac{25 \text{ kg/mm}^2}{\text{W.S}}$

WS =  $\frac{25}{4} \text{ kg/mm}^2$

= 6.25 kg/mm<sup>2</sup>

Stress =  $\frac{F}{A}$

6.25 kg/mm<sup>2</sup> =  $\frac{F \text{ kg}}{\pi \times 2.1 \times 2.1 \text{ mm}^2}$

F = 6.25 × π × 2.1 × 2.1 kg

Safe load F = 86.6 kg

## Assignment

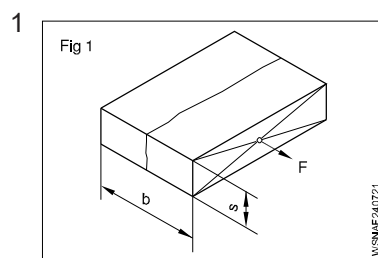

A = 60 × 15 mm<sup>2</sup>

Rm = 370 N/mm<sup>2</sup>

F = \_\_\_\_\_ N

Rm = Ultimate stress

F = Breaking Force

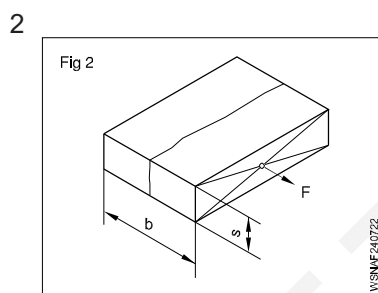

A = 25 × 6 mm<sup>2</sup>

F = 63000 N

Rm = \_\_\_\_\_ N/mm<sup>2</sup>

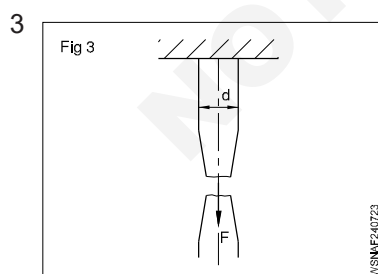

A = 490.87 mm<sup>2</sup>

F = 206.22 kN

d = \_\_\_\_\_ mm

Rm = \_\_\_\_\_ N/mm<sup>2</sup>

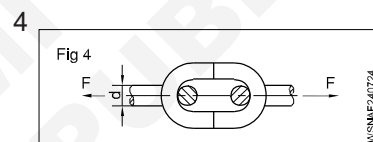

F = 19000 N

Rm = 420 N/mm<sup>2</sup>

Factor of safety = 5

d = \_\_\_\_\_ mm

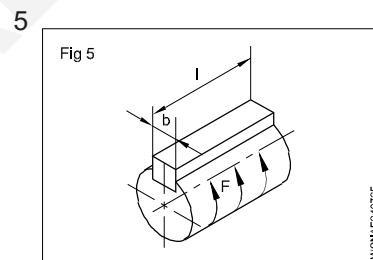

F = 35000 N

Working shear stress = 110 N/mm<sup>2</sup>

b = 10 mm

l = \_\_\_\_\_ mm

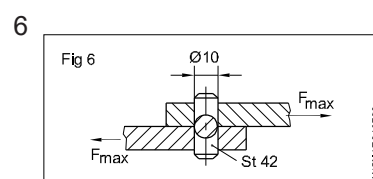

Ultimate tensile stress = 420 N/mm<sup>2</sup>

d = 10 mm

Shear force Max = \_\_\_\_\_ N

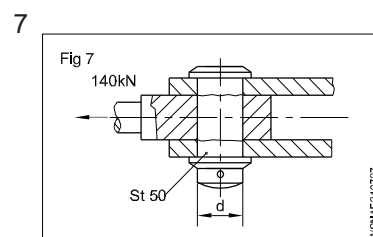

F = 140 kN (Tensile)

Factor of safety = 4

Ultimate tensile stress = 500 N/mm<sup>2</sup>

Ultimate shear stress = 400 N/mm<sup>2</sup>

d = \_\_\_\_\_ mm

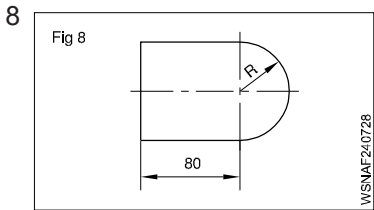

Ultimate tensile strength =  $370 \text{ N/mm}^2$   
 Shear force =  $380 \text{ kN}$   
 $R = 30 \text{ mm}$   
 Thickness of plate punched = \_\_\_\_\_ mm

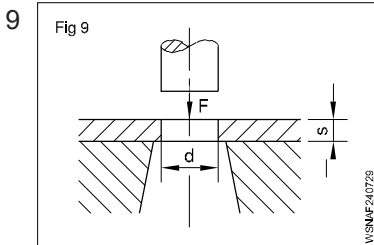

Ultimate tensile strength =  $330 \text{ N/mm}^2$   
 $s = 3 \text{ mm}$   
 $F = 60 \text{ kN}$  (Shear force)  
 $d =$  \_\_\_\_\_ mm

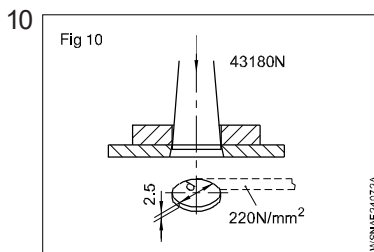

$F = 43180 \text{ N}$   
 $s = 2.5 \text{ mm}$   
 Ultimate tensile strength =  $220 \text{ N/mm}^2$   
 $d =$  \_\_\_\_\_ mm

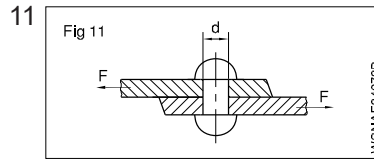

$d = 12 \text{ mm}$   
 $F = 36.2 \text{ kN}$   
 Ultimate tensile strength = \_\_\_\_\_  $\text{N/mm}^2$

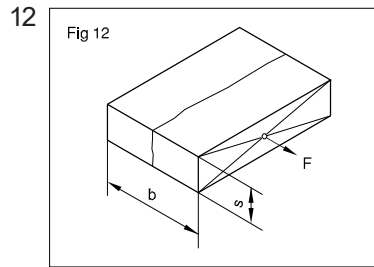

Tensile load =  $15000 \text{ N}$   
 Ultimate tensile strength =  $9.5 \text{ N/mm}^2$   
 $s = 20 \text{ mm}$   
 Width 'b' = \_\_\_\_\_ mm

13 Find out the load which can be suspended from a  $3.2 \text{ mm}$  dia wire taking the factor of safety as 2. Ultimate stress is  $25 \text{ kg/mm}^2$ .

14 A rod of  $60 \text{ mm}$  dia is subjected to a maximum tensile load of  $1600 \text{ kg}$ . Calculate the stress and strength of the material if the factor of safety is 5.



## Estimation and Costing - Simple estimation of the requirement of material etc., as applicable to the trade

### Introduction

Estimation is the method of calculating the various quantities and the expenditure to be incurred on a particular job or process.

Estimate is the method used to measure or quantify the different quantities and the expected expenditure to be incurred on a particular work or project.

We know that the estimation is long procedure, and its totally depends upon the projects,

In case the funds available are less than the estimated cost the work is done in part or by reducing it or specifications are altered,

The following essential details are required for preparing an estimate.

Drawings like plan, elevation and sections of important parts.

Detailed specifications about workmanship & properties of materials, etc.

Standard schedule of rates of the current year.

Estimating is the process of preparing an approximation of quantities which is a value used as input data and it is derived from the best information available.

An estimate that turns out to be incorrect will be an overestimate if the estimate exceeded the actual result, and an underestimate if the estimate fell short of the actual result.

A cost estimate contains approximate cost of a product process or operation. The cost estimate has a single total value and it is inclusive of identifiable component values.

### Purpose of Estimating and Costing

- 1 Estimates provide an rough idea of the cost of the job and therefore its feasibility can be calculated, i.e. whether or not the project would be included in the funds available.
- 2 Estimate gives an idea of the time needed to complete the work.
- 3 Estimates are required to invite tenders and quotations and to arrange the contracts.

4 Estimates are also required to control expenditure during the execution of the work.

5 Estimates decide whether or not proposed plan matches the funds available.

### Estimation Methods

Estimate involves the following operations

- Preparing detailed Estimate.
- Calculating the rate of each unit of work.
- Preparing abstract of estimate.

**Estimation** is the process of calculating or evaluating a quantity by estimation, that is, without reference to specific measurements. Estimating is a fundamental process in all engineering.

This is usually done before purchase or construction begins or during preliminary planning stages. Estimating is usually more accurate, but there are a few limitations - namely that if your estimate relies on labour costs, you'll need to know how many man-hours will take to complete the project.

Estimates are developed from observations and knowledge of past experience. The accuracy of an estimate often depends on the level of detail available and the amount of time for which data are available for analysis.

**Costing** is the process of estimating the cost of a project before it's completed. It can be done with an itemized list, or through estimation using a construction cost calculator.

Costing includes three steps: estimating, bidding, and finalizing. It helps predict how much money will be required to construct the project.

A "costing" typically refers to how much it will cost someone to produce a single unit.

### There are two types of costings

**Independent costing** - this is the cost of direct material and labour costs. This type of costing only takes into account the cost of a single-phase, so it's not representative of the overall project cost.

**Cumulative Costing** - this type of costing looks at the total cost for all phases of work, but it can be difficult to ensure that estimates are accurate.

### Exercise

- 1 Find the volume and total cost of material for the given object. The size of the raw material is 550mm x 80mm x 1.5mm thick. Density of the material is 2.8 gm/cm<sup>3</sup> and the cost of the material is Rs.250/Kg. (Fig 1)

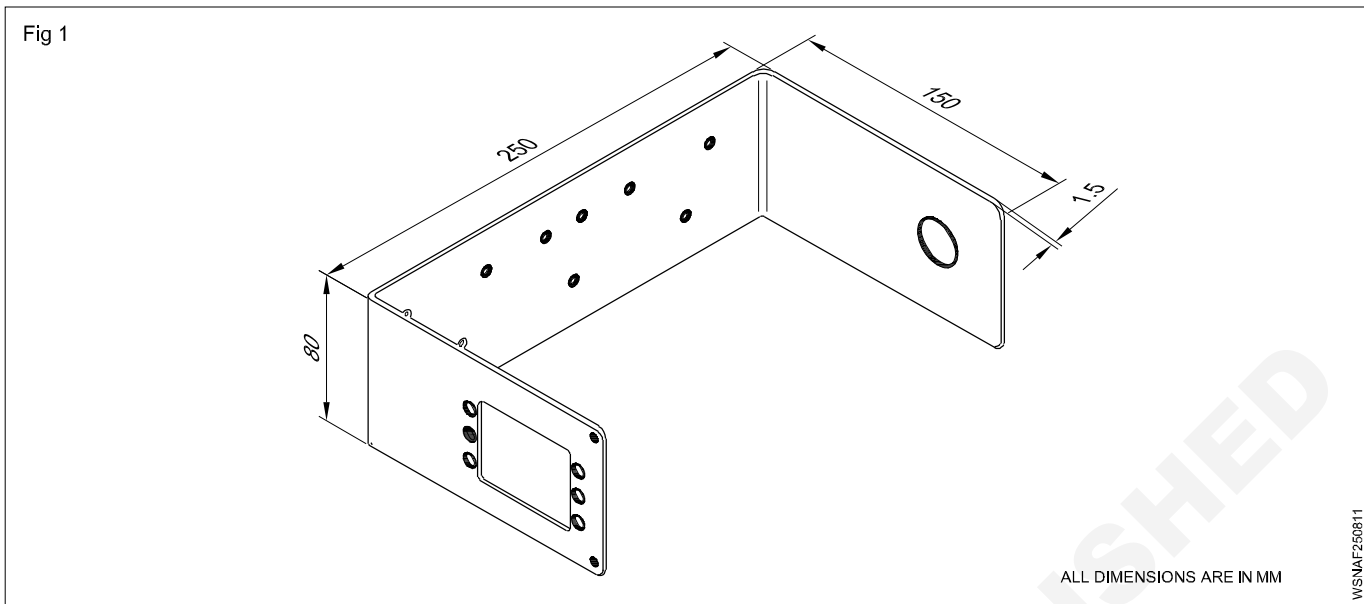

Length ( $\ell$ ) of the object =  $250 + 150 + 150$   
 $550 \text{ mm} = 55 \text{ cm}$

Width ( $b$ ) =  $80 \text{ mm} = 8 \text{ cm}$

Thickness ( $t$ ) =  $1.5 \text{ mm} = 0.15 \text{ cm}$

Volume =  $\ell \times b \times t \text{ unit}^3$   
 $= 55 \times 8 \times 0.15 \text{ cm}^3$

Volume =  $66 \text{ cm}^3$

Weight = Volume x Density

Density =  $2.8 \text{ gm/cm}^3$   
 $= 66 \text{ cm}^3 \times 2.8 \text{ gm/cm}^3$   
 $= 184.8 \text{ grams}$

Weight =  $0.1848 \text{ Kg}$

Cost of the material =  $\text{Rs.}250/\text{Kg}$   
 $= 0.1848 \times \text{Rs.}250$   
 $= \text{Rs.}46.2$   
 $= \text{Rs.}46$

2 Calculate the material cost of the given CFRP (Carbon Fibre Reinforced Plastic) angle, if the cost of the material is Rs.900/Kg and the density is 1.93 gm/cm<sup>3</sup>. (Fig 2)

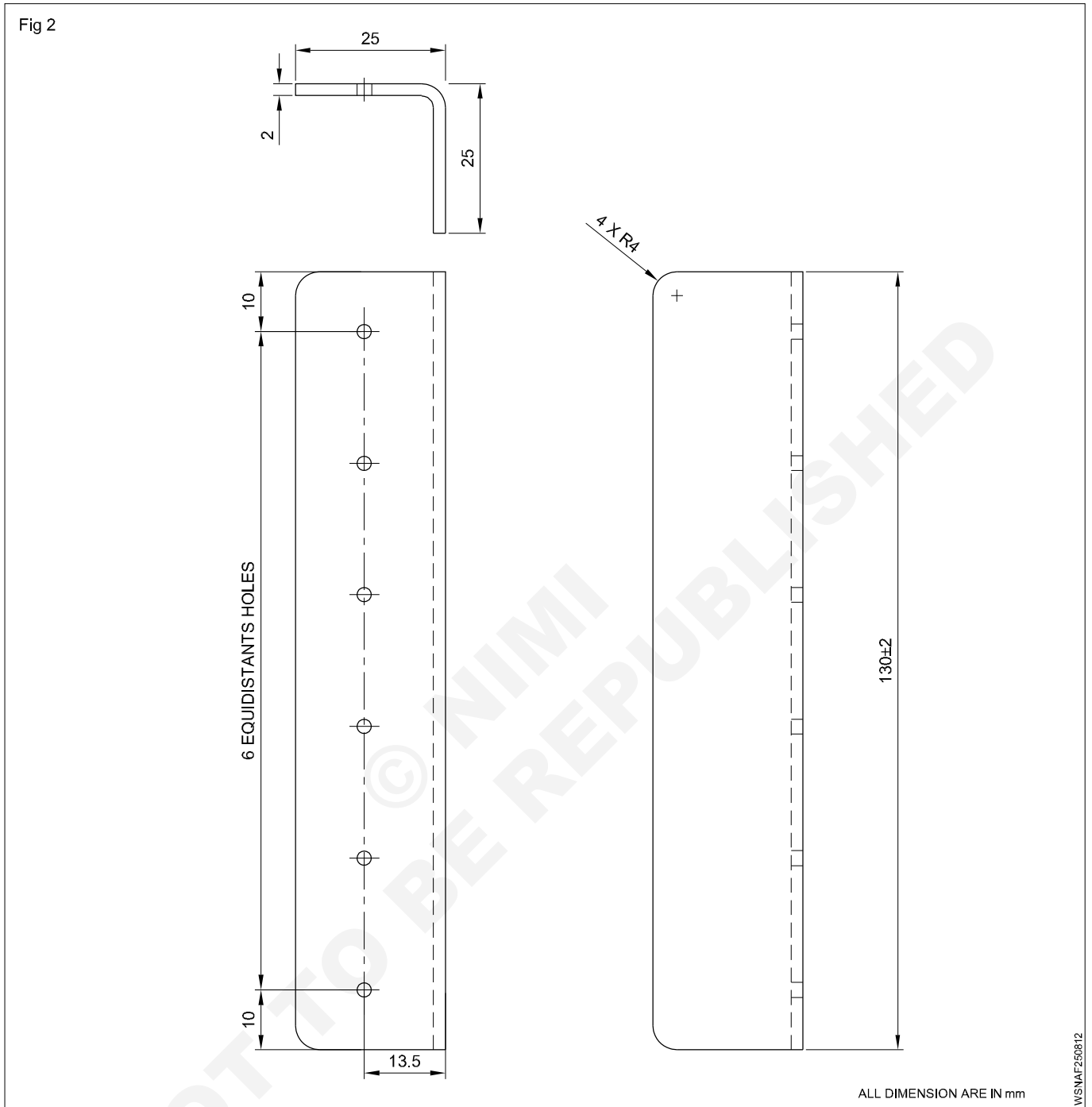

Stock size of the angle = 25 x 25 - L 130

Length ( $\ell$ ) = 130mm = 13 cm

Width (b) = 25 + 25 = 50mm = 5cm

Thickness (t) = 2mm = 0.2 cm

Volume of the angle =  $\ell \times b \times t$  unit<sup>3</sup>  
 = 13 x 5 x 0.2 cm<sup>3</sup>  
 = 13 cm<sup>3</sup>

$$\begin{aligned}
 \text{Weight of the angle} &= \text{Volume} \times \text{Density} \\
 &= 13 \text{ cm}^3 \times 1.93 \text{ gm/cm}^3 \\
 &= 25.09 \text{ grams} \\
 &= 0.025 \text{ Kg} \\
 \text{Cost of the material} &= \text{Rs.}900/\text{Kg} \\
 \text{Cost of the angle} &= 0.025 \times \text{Rs.}900 \\
 &= \text{Rs.}22.5 \\
 \text{Cost of the angle} &= \text{Rs.}23
 \end{aligned}$$

3 What is the volume and material cost of the plate made of AISI 316 L(S.S) material whose density is  $8 \text{ gm/cm}^3$  and material cost is Rs.280/Kg. (Fig 3)

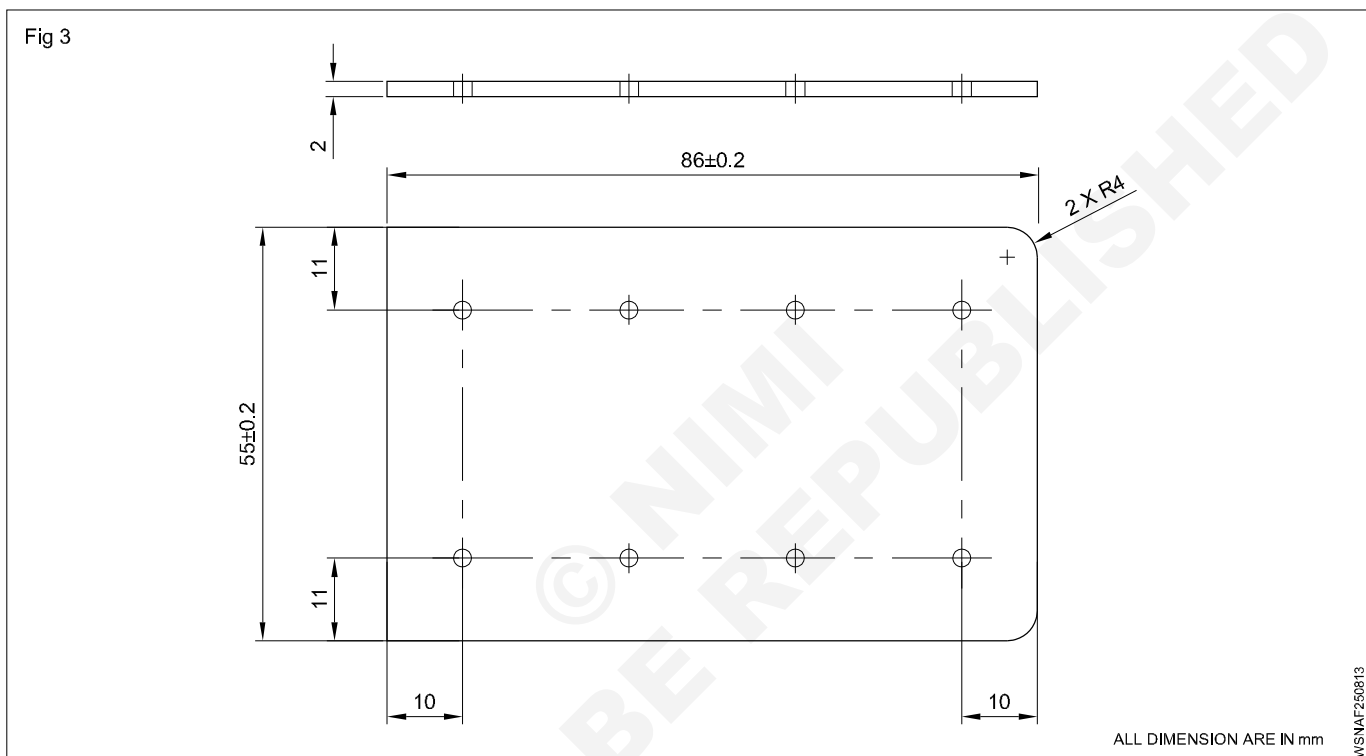

$$\begin{aligned}
 \text{Stock size of the sheet} &= 55 \times 86 - \text{Thick } 2 \\
 \text{Length } (l) &= 86 \text{ mm} = 8.6 \text{ cm} \\
 \text{Width } (b) &= 55 \text{ mm} = 5.5 \text{ cm} \\
 \text{Thickness } (t) &= 2 \text{ mm} = 0.2 \text{ cm} \\
 \text{Volume of the sheet} &= l \times b \times t \text{ unit}^3 \\
 &= 8.6 \times 5.5 \times 0.2 \text{ cm}^3 \\
 &= 9.46 \text{ cm}^3 \\
 \text{Weight of the sheet} &= \text{Volume} \times \text{Density} \\
 &= 9.46 \text{ cm}^3 \times 8 \text{ gm/cm}^3 \\
 &= 75.68 \text{ grams} \\
 &= 0.075 \text{ Kg} \\
 \text{Cost of the material} &= \text{Rs.}280/\text{Kg} \\
 \text{Cost of the sheet} &= 0.075 \times \text{Rs.}280 \\
 &= \text{Rs.}21
 \end{aligned}$$

4 What is the cost of the standard anodized dichromated 6000 series aluminium alloy rail of length 65mm x 4 Nos., if the cost of the rail is Rs.400/metre. (Fig 4)

Length of the Rail = 65mm  
 = 0.065 metre  
 Cost of the Rail = Rs.400/meter  
 = 0.065 x 400  
 For 1 No. = Rs.26  
 For 4 Nos. = Rs.26 x 4  
 = **Rs.104**

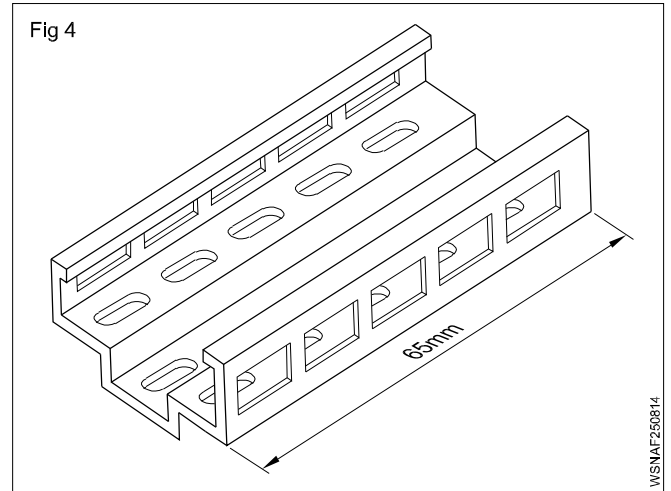

5 Calculate the volume and cost of the material for the given object shown in the figure. The size of the material is 88mm sq x 16mm Thick. Density of material is 2.8 gm/cm<sup>3</sup> and the cost of the material is Rs.250/Kg. (Fig 5)

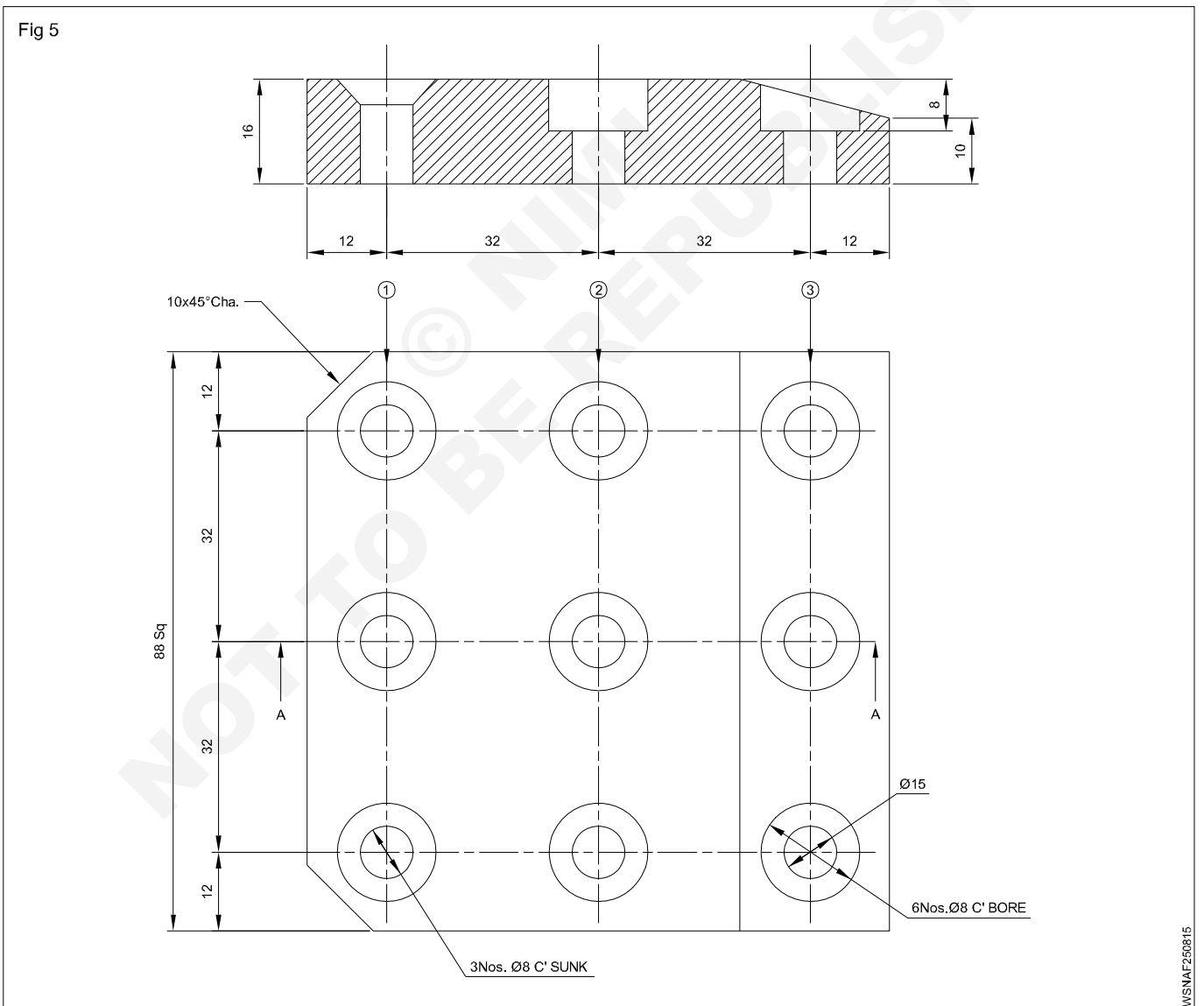

Stock size = 88mm sq x 16mm Thick

Size of the plate (a) = 88 mm sq  
= 8.8 cm

Thickness of the plate (t) = 16 mm  
= 1.6 cm

Volume of the plate =  $a^2 t$  unit<sup>3</sup>  
= 8.8 x 8.8 x 1.6 cm  
= 123.904 cm<sup>3</sup>

Weight of the plate = Volume x Density  
= 123.904 cm<sup>3</sup> x 2.8 gm/cm<sup>3</sup>  
= 346.93 grams  
= 0.346 Kg

Cost of the material = Rs.250/Kg

Cost of the plate = 0.346 x Rs.250  
= Rs.86.5

**Cost of the plate = Rs.87**

Estimation and Costing - Problems on estimation and costing

1 Find the total estimation cost of material and machining cost for the angle as shown in the fig. Labour charge is R.150/hour and material cost is Rs.23 (Ref. Ex. 2.5.08 : Q.No.2)

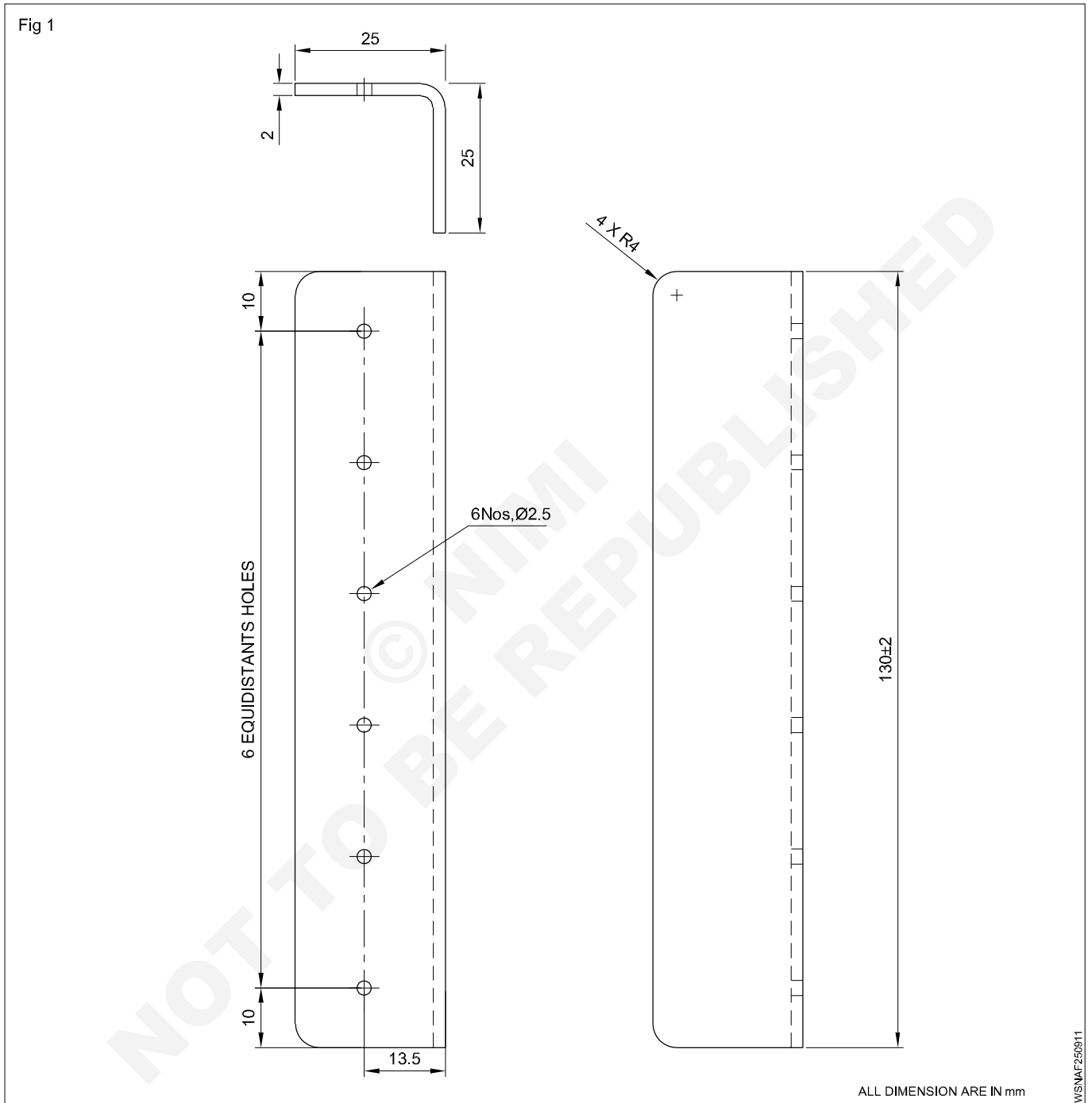

1	Mark the external dimensions and radii	30 mins
2	File the external dimension and radii and deburr edges	30 mins
3	Mark the hole positions and drill the holes Ø2.5 mm x 6 Nos. with hand drill	60 mins
<b>Total</b>		<b>120 mins</b>

**Calculation:**

Total time = 120 mins

Hours =  $\frac{120}{60} = 2$  hours

Labour charge = Rs.150/hour

Filing and Drilling charges = 2 x 150  
= Rs.300

Total cost = Filing and drilling cost + Material cost  
= Rs.300 + Rs.23  
= **Rs.323**

**2 Calculate the total estimation cost of the component given in the figure. Machining cost is Rs.300/hour and Material cost is Rs.87 (Ref. Ex. 2.5.08 : Q.No.5)**

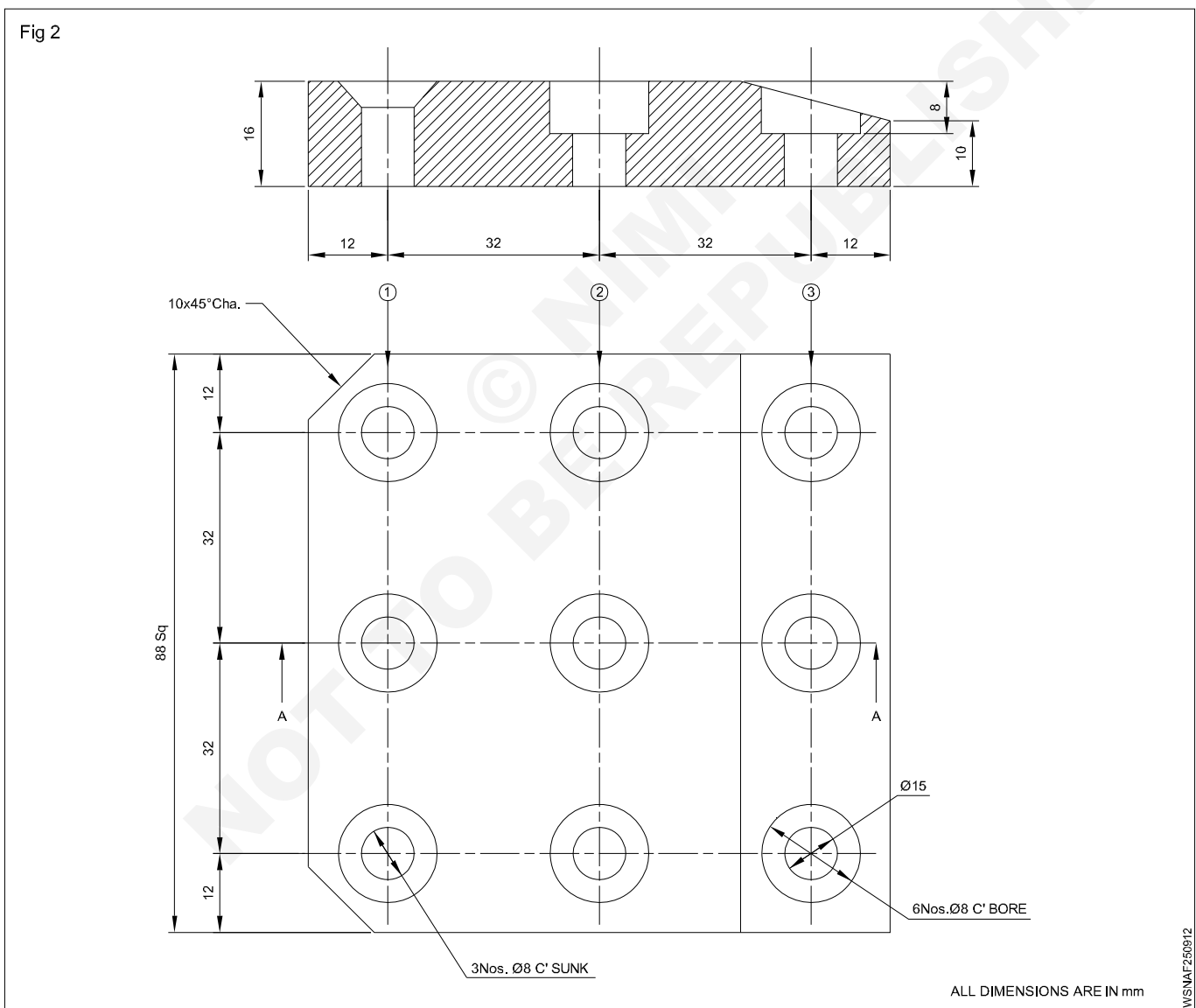



1	Marking the hole positions	30 mins
2	Punch the centres	30 mins
3	Hold the workpiece and holes to diameter 8 mm x 9 holes	90 mins
4	Hold the workpiece on the machine vice and set the counter sinking depth	30 mins
5	Set the counter boring depth with depth gauge	60 mins
6	Spot face	30 mins
7	Finish with the chamfer on the both ends	30 mins
<b>Total</b>		<b><u>300 mins</u></b>

**Calculation:**

Total time = 300 mins

Hours =  $\frac{300}{60} = 5$  hours

Labour charges = Rs.300/hour

Machining cost = 5 hours x Rs.300  
= Rs.1500

Total cost = Material cost + Machining cost  
= Rs.87 + Rs.1500

**Total cost = Rs.1587**